



SERVICE BULLETIN

No. 464A

Piper Aircraft Corporation

Lock Haven, Pennsylvania, U.S.A.

"DOA EA-1 Approved"

March 22, 1976

S/M

(Supersedes and voids Service Bulletin No. 464 Dated September 4, 1975).

Subject:

Inspection of Stabilator Torque Tube Bearing Block Attachment Fitting Rivets.

Reason for Revision:

1. Clarification to Instructions No. 3, (below) regarding rivet "alignment" vs. rivet "alignment/penetration".
2. Changed Material Required section; one kit per fitting (was one kit per aircraft).

Models Affected:

PA-24-180, PA-24-250, and
PA-24-260 Comanche
PA-24-400 Comanche
PA-30 Twin Comanche
PA-39 Twin Comanche

Serial Numbers Affected:

24-1 to 24-5047 Inclusive
26-2 to 26-148 Inclusive
30-1 to 30-2000 Inclusive
39-1 to 39-155 Inclusive

NOTE:

Above referenced aircraft that have complied with Piper Service Bulletin No. 411A dated April 10, 1974, and have had kit 760 835 (Hi Shear Rivet Replacement) installed in all four Stabilator Torque Tube Bearing Block Attachment Fittings do not require inspection per this Service Bulletin, as the Hi Shear Rivet Replacement has remedied this condition. Aircraft that have had kit 760 835 installed in less than four bearing block attachment fittings require inspection only of the fittings that have not been modified.

Compliance Time:

At the next 100 hour or annual inspection, not to exceed the next fifty (50) hours of operation. Repeat compliance (for aircraft that have complied with Service Bulletin No. 464 dated September 4, 1975) not required.

Purpose:

In some instances, while complying with Piper Service Bulletins Nos. 411 and 411A, it was determined that the rivets which attach the aft fuselage skin to the adjacent aft fuselage stringer align with some of the rivets which secure the Stabilator Torque Tube Bearing Block Attachment Fittings to the adjacent aft fuselage stringers. The fittings (particularly the lower fittings) are drilled to allow clearance for the heads of the rivets which attach the fuselage skin. In some cases, the rivet clearance holes were drilled too deep, thus allowing drill penetration of the

(over)

Purpose (Continued):

Stabilator Bearing Block Attachment Fitting Rivets (see sketch for an illustration of this condition).

A study was conducted to determine the significance of the above described condition. It was subsequently determined that the rear corner rivet in the bearing block fitting (which is most susceptible to drill penetration) is redundant to the structural integrity of the fitting assembly, and also that one additional rivet located in the bearing block could be removed without reducing the strength of the assembly below an acceptable value. However, if more than two rivets per fitting (described above) have been penetrated during the drilling operation, it will be necessary to install one (1) each per fitting Piper Kit Number 760 835, Hi Shear Rivet Replacement, and install bolts (per kit instructions) in place of the existing rivets in those bearing blocks which contain more than two rivets penetrated during drilling.

NOTE:

In some instances rivet alignment may be detected during the inspection referred to in Instructions, below, and on the attached sketch/instructions sheet. However, closer inspection may reveal that, although rivet alignment may exist, rivet penetration may not have occurred--in which case, no further action is required.

Instructions:

1. Remove the rear fuselage access panel located on the right side of the aircraft just forward of the stabilator.
2. Using a light and mirror (with extension), view through this access opening to determine if any of the horizontally positioned rivets through the skin align with any of the vertically positioned rivets in the bearing block (refer to attached sketch).
3. If more than two (including the corner rivet) rivet alignments/penetrations in any bearing block fitting have been ascertained, installation of Kit Number 760 835 is required in the affected bearing block fitting. Two rivet alignments/penetrations or less as described in paragraph 2, Purpose, above, requires no further action except for the appropriate log book entry.

Material Required:

1. One (1) each PER FITTING (i.e., each kit contains sufficient material to modify one only Stabilator Torque Tube Bearing Block Fitting), Piper Kit Number 760 835, Hi Shear Rivet Replacement, if required per Instructions number 3, above.
2. Two (2) each per aircraft Cover Plate, Part Number 28216-02, if installation of Kit 760 835 is required per Instructions number 3, above.

Availability of Parts:

Your Piper Field Service Facility.

Effectivity Date:

This Service Bulletin is effective upon receipt.

Summary:

Please contact your Piper Field Service Facility to make arrangements for compliance with this Service Release in accordance with Compliance Time, above. Material required, if necessary, will be provided free of charge through your Piper Field Service Facility.

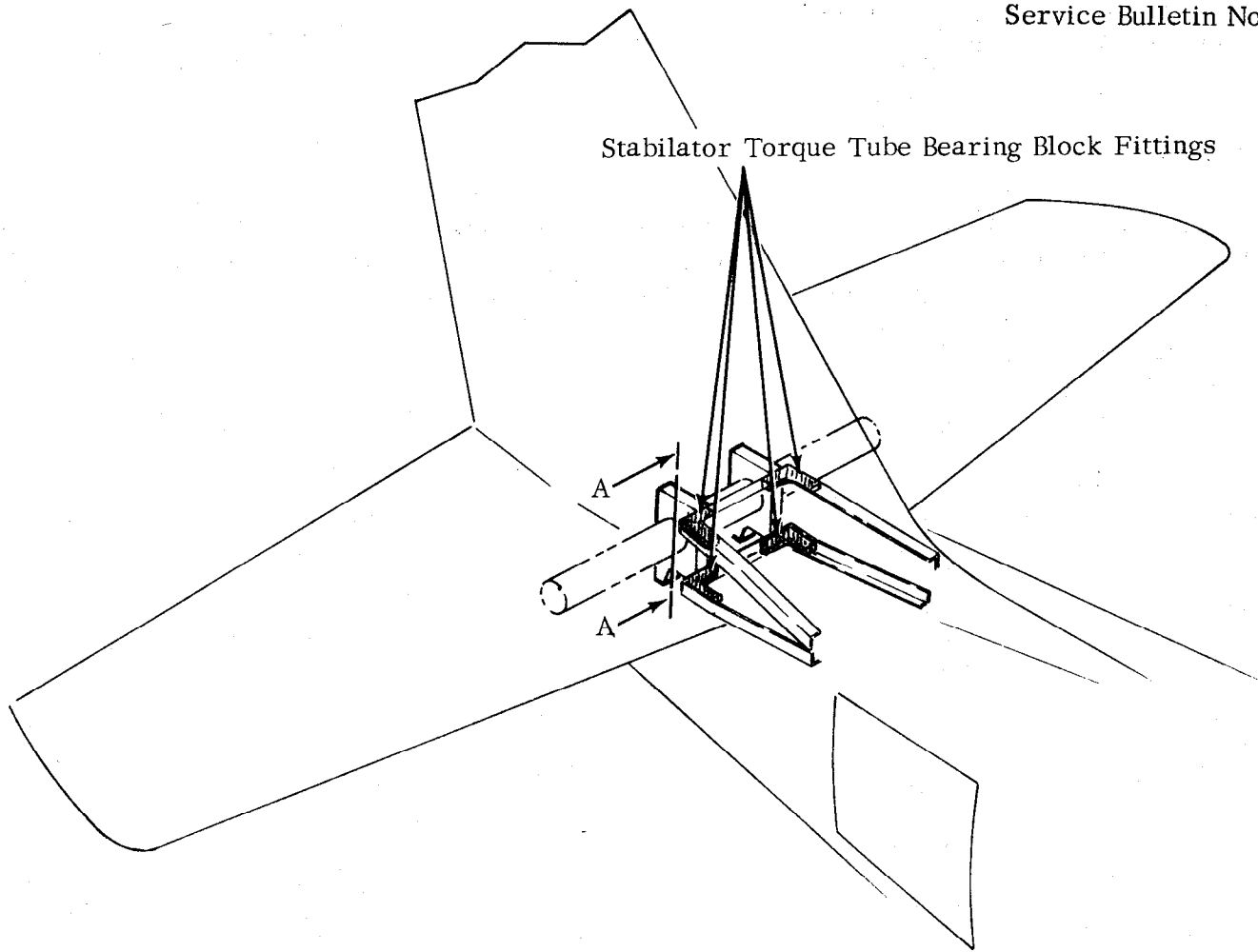

FWD

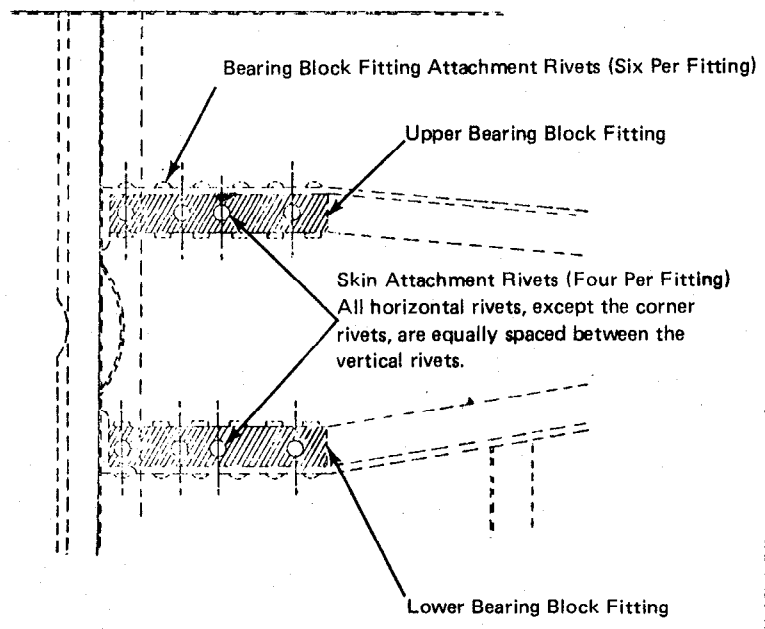

VIEW A-A: CORRECT RIVET ALIGNMENT

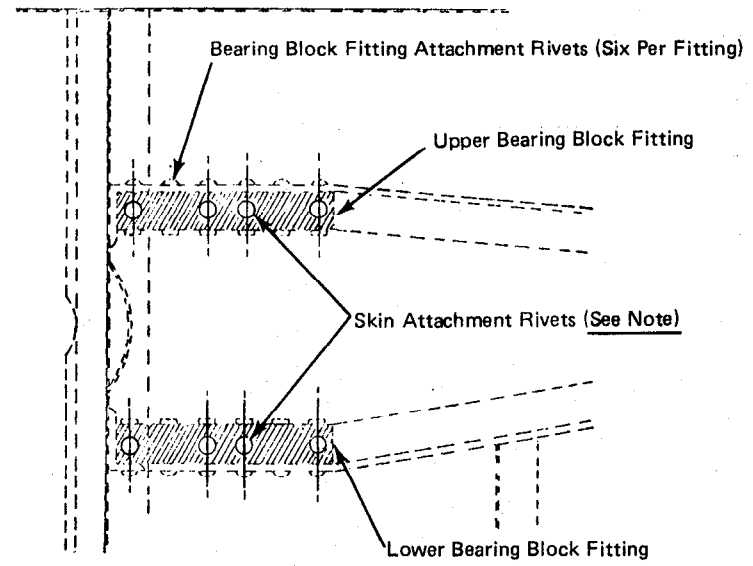

VIEW A-A: RIVET ALIGNMENT which may have resulted in rivet penetration:

NOTE: All horizontal rivets, except the corner rivets, are incorrectly installed in this view as they are aligned with the vertical rivets. If more than two rivet alignments are evident in each fitting, it will be necessary to install Kit 760 835.