



SERVICE LETTER

No. 695

Piper Aircraft Corporation

Lock Haven, Pennsylvania, U.S.A.

May 3, 1974 S/M

Subject: Roll Servo Inspection, Maintenance and Shear Pin Installation -- reference attached Edo-Aire Mitchell Service Letter No. ML38, dated March 18, 1974.

Models and Serial Numbers Affected: All Piper airplanes with a Piper II Series AutoPilot Installation.

Compliance Time: Recommended at the next 100-hour inspection or annual inspection, whichever occurs first.

Purpose: To provide distribution of Edo-Aire Mitchell's Service Letter No. ML38, dated March 18, 1974, concerning proper inspection and maintenance procedures for the roll servo and the shear rivet installation which will disconnect the roll servo from the control system whenever pilot forces exceed a pre-determined value (this feature is in addition to the existing pilot override capabilities of the AutoPilot systems). Refer to attached copy of Edo-Aire Mitchell Service Letter No. ML38 for additional details.

Instructions: Refer to attached copy of Edo-Aire Mitchell Service Letter No. ML38.

Material Required:

1. Silicone Lubricant, Piper Part No. 761 180 (General Electric Part No. G-322L, two ounce tube), at a suggested unit list price of \$3.23C.
2. Shear Rivet, Piper Part No. 420 222 (AN470AD4-10), at a suggested unit list price of \$.02C.
3. Locking Ring, Edo-Aire Mitchell Part No. 42S283 (TRUARC Part No. 5100-39) or Locking Ring, Edo-Aire Mitchell Part No. 42S149 (TRUARC Part No. 5110-43), whichever is applicable -- refer to Edo-Aire Mitchell Service Letter No. ML38, Page 3; available either through Edo-Aire Mitchell or procure locally.

Availability of Parts: Your Piper Field Service Facility.

Effectivity Date: This Service Letter is effective May 20, 1974



SERVICE

LETTER

NO ML-38

DATE 3-18-74

FAA Approved

EDO-AIRE MITCHELL

TO Edo-Aire Mitchell Distributors,
Piper Aircraft Corporation, and
Owners of Aircraft having the
Autopilot Kits, Listed on Pages
4 and 5 Installed

SUBJECT Roll Servo Inspection, Maintenance,
and Shear Pin Installation

APPLICABILITY

This Service Letter applies to autopilots installed under the STC's in the aircraft listed on Pages 4 and 5. A recent incident has been reported wherein a pilot experienced a restriction to the aileron control in one of the affected aircraft. A thorough investigation revealed the restriction was caused by improper operation of the autopilot roll servo, and that the improper servo operation resulted from a lack of periodic preventative maintenance being performed upon the autopilot system. The Federal Aviation Regulations do require periodic preventative maintenance upon aircraft and the systems installed therein, such as during Annual Inspections. The inspection and maintenance items covered in this Service Letter are applicable to the periodic Annual Inspections.

A Shear Pin Modification for the subject installations is available and it should be installed at the next Annual Inspection. The installation of this modification will provide an additional reserve against any future occurrence of aileron control restriction. This shear pin feature will disconnect the roll servo from the control system whenever pilot forces exceed a predetermined value. The reserve is in addition to the existing pilot override capabilities of the autopilot systems.

The following should be performed at the next Annual Inspection, or immediately if any abnormal operation or restriction of the aileron control system has been experienced, or is suspected to exist.

DISASSEMBLY AND INSPECTION

1. The roll servo of the affected autopilot models is mounted on the forward side of the firewall or forward cabin bulkhead, the right hand control column on some PA-23 and PA-22 Models, or on the tee bar of early PA-28 and PA-32 aircraft.
2. Determine whether the pilot can override the roll servo slip clutch. This may be done by engaging the roll servo with the autopilot "ON", and with the servo not running, manually overriding the aileron control at the wheel. If the pilot is unable to override the slip clutch, the proper slip force must be readjusted, or the servo may be returned to Edo-Aire Mitchell for factory service. (Reference: Clutch settings given on Pages 4 and 5.)

3. Locate the roll servo and control shaft assembly. Disconnect all electric power cables and extensions to the servo.
4. Remove the 6-32 screws that retain the servo cover, and remove the cover.
5. Inspect the roll servo actuator assembly for any abnormalities, such as corrosion, excessive wear, loose fasteners, inoperative components, dirt accumulation, or lack of lubrication. Take corrective action as indicated by the inspection. (See below if re-lubrication is required.)

SHEAR PIN INSTALLATION AND LUBRICATION

1. Locate the 22S12 Roll Pin (1/8 dia. x 11/16 long). Reference ML-38 Reference Drawing, Page 6. This roll pin, which secures the servo output gear and override shaft assembly to the wheel column extension shaft is to be removed after an appropriate mark is made to identify the gear and shaft orientation. When removing the roll pin support the shaft so that the shaft will not be damaged during pin removal. A suitable tool can be made from a "C" clamp to aid removal. When the servo is reassembled, the original orientation must be restored because of the preset timing of the autopilot follow up condenser. After the 22S12 roll pin is removed, the servo should be removed by sliding the unit off the wheel column extension shaft. Inspect the extension shaft and servo override shaft assembly for dirt and/or corrosion, cleaning if necessary. Also, if inspection of the roll servo indicates new lubrication is required, all traces of the old lubricant should be removed. A suitable solvent may be used, however, care is required so as not to contaminate the servo motor, clutch surfaces, or electrical components attached to the servo. Relubricate the operating surfaces of the gears and shaft assembly, and the wheel column extension shaft with a light film of the following lubricant:

EDO-AIRE MITCHELL P/N 11M291
(General Electric Silicone Lubricant G-322L)

The lubricant, P/N 11M291, may be ordered from Edo-Aire Mitchell, P.O. Box 610, Mineral Wells, Texas, 76067, or it may be purchased from General Electric as their Silicone Lubricant, P/N G-322L.

2. Reassemble the roll servo on the extension shaft, noting the orientation marks previously made. Instead of the 22S12 Roll Pin, install the 5S103 Rivet (AN470AD4-10). After the rivet is installed, buck lightly to retain.

WARNING: The 5S103 Rivet is an AN rivet P/N AN470AD4-10. The material (Aluminum Alloy #2117T-4) was chosen for its shear characteristics.
DO NOT USE ANY OTHER RIVET FOR THIS APPLICATION.

3. A locking ring is to be installed over the free overhang length of the control column extension shaft on models which do not have a servo securing device, (either a castle nut with cotter pin, or a bolt and nut through the shaft in the free overhang length). The purpose of these securing devices is to secure the roll servo on the shaft following a shear pin failure.

Determine the diameter of the wheel column extension shaft. The various affected autopilot models have roll servos with two shaft sizes: .375" diameter, and .434" diameter. Use Locking Ring, P/N 42S283 (TRUARC P/N 5100-39) for a .375" diameter shaft, or a Locking Ring, P/N 42S149 (TRUARC P/N 5110-43) for a .434" diameter shaft. The locking ring is to be installed with the stamping radius on the AFT (inward) side.

REASSEMBLY

The roll servo cover is to be installed on the servo with the 6-32 screws previously removed. All electrical cables and cable extensions are to be inserted into their original connectors.

GROUND CHECK

1. Operation - Autopilot Off

Rotate control wheel left and right to insure full aileron control system travel. Check for restrictions or binding, correct any deficiency found.

2. Operation - Autopilot On

Check force required to manually overpower the roll servo slip clutch (Ref. Page 4). Readjust the clutch as necessary to maintain the load limits specified on the control wheel.

PARTS

The parts required to comply with ML-38 can be ordered by individual part numbers through any Edo-Aire Mitchell Distributor, or direct from the factory. They may also be ordered direct from the original suppliers, using the original suppliers' part numbers given in ML-38.

AIRCRAFT MAINTENANCE RECORD

After accomplishing the above steps this Service Letter should be placed with aircraft maintenance records and a log book entry made to reflect compliance with Edo-Aire Mitchell Service Letter ML-38.

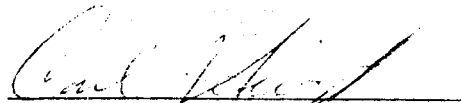

Carl J. Swift
Director, Products and Service

AFFECTED AUTOPILOT INSTALLATIONS
FOR SERVICE LETTER ML-38
(PIPER AUTOCONTROLS AND ALTIMATICS)

AP MODEL	AC MODEL	AK NO.	STC NO.	ROLL INSTL DWG.	SERVO P/N	CLUTCH SET. AT SERVO	CONTROL WHEEL FORCE*
ALT. II	PA-23	AK090	SA363SW	69D340	1X221E-A	60 ± 5	16 ± 3
ALT. II	PA-23-160	AK090	SA363SW	69D340	1X221E-A	60 ± 5	16 ± 3
ALT. II	PA-23-235	AK090	SA363SW	69D340	1X221E-A	60 ± 5	16 ± 3
ALT. II	PA-23-250	AK090	SA363SW	69D340	1X221E-A	60 ± 5	16 ± 3
ALT.	PA-23-250	AK081 AK081R	SA-2-960	69D158	1X216-A 1X231-A	60 ± 5	16 ± 3
AUTO- CONTROL	PA-24	AK066	SA-2-409	69D75	1X216 (CO)	60 ± 5	16 ± 3
ALT.	PA-24	AK083 AK083R	SA-2-930	69D157	1X216-C 1X231-C	60 ± 5	16 ± 3
ALT. II	PA-24	AK089 AK089R	SA59SW	69D221 69D223	1X216-C 1X231-C	60 ± 5	16 ± 3
AUTO- CONTROL	PA-24-250	AK066	SA-2-409	69D75	1X216 (CO)	60 ± 5	16 ± 3
ALT.	PA-24-250	AK083 AK083R	SA-2-930	69D157	1X216-C 1X231-C	60 ± 5	16 ± 3
ALT. II	PA-24-250	AK089 AK089R	SA59SW	69D221 69D223	1X216-C 1X231-C	60 ± 5	16 ± 3
ALT. II	PA-24-260	AK089 AK089R	SA59SW	69D221 69D223	1X216-C 1X231-C	60 ± 5	16 ± 3
ALT. II	PA-24-400	AK089 AK089R	SA59SW	69D221 69D223	1X216-C 1X231-C	60 ± 5	16 ± 3
ALT. II	PA-30	AK089 AK089R	SA59SW	69D221 69D223	1X216-C 1X231-C	60 ± 5	16 ± 3
AUTO- CONTROL	PA-22	AK064	SA-2-359	69B60	1X216 (TRI)	55 ± 5	16 ± 3
AUTO- CONTROL II	PA-28-150	AK085E	SA236SW	69D291	1X221E-CH1	60 ± 5	16 ± 3
AUTO CONTROL II	PA-28-160	AK085E	SA236SW	69D291	1X221E-CH1	60 ± 5	16 ± 3
AUTO CONTROL II	PA-28-235	AK085E	SA236SW	69D291	1X221E-CH1	60 ± 5	16 ± 3
ALT. II	PA-32-260	AK175	SA538SW	69D446	1X221E-175	60 ± 5	16 ± 3

AP MODEL	AC MODEL	AK NO.	STC NO.	ROLL INSTL DWG.	SERVO P/N	CLUTCH SET. AT SERVO	CONTROL WHEEL FORCE*
AUTO- CONTROL	PA-23 PA-23-160	AK067	SA2-845	69D80	1X216	NA	16 ± 3
AUTO- PILOT	PA-23 PA-23-250 PA23-160	AK079E	SA-2-925	69D189	1X221-E-AZ	NA	18 ± 3
AIRBOY	PA-24 PA-24-250	AK065E	SA2-402	69DA2	1X221E- COM	NA	16 ± 3

*Force in lbs. measured at the maximum radius of the control wheel.

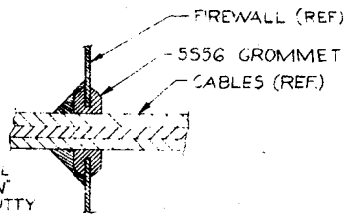

SEAL CABLES THRU FIREWALL WITH BF GOODRICH "PLASTIKON" #21 RUBBER PUTTY. SHAPE PUTTY ON ENGINE SIDE TO 45° CONICAL WITH BASE DIAMETER TWICE HOLE DIAMETER.

SECTION A-A

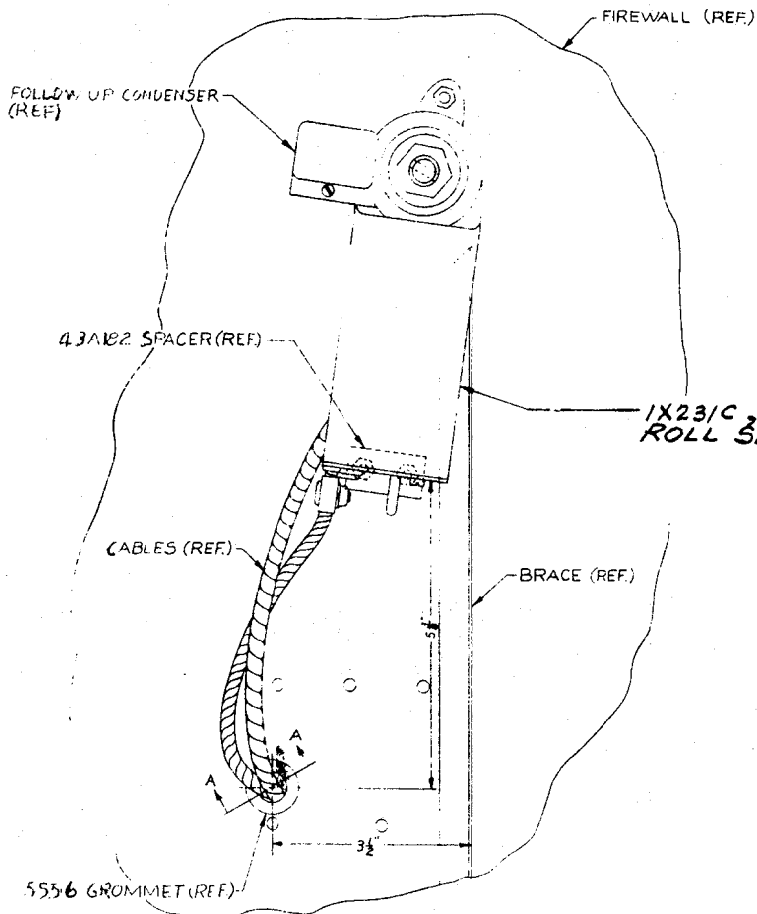

VIEW LOOKING AT ENGINE SIDE OF FIREWALL - PILOT'S SIDE

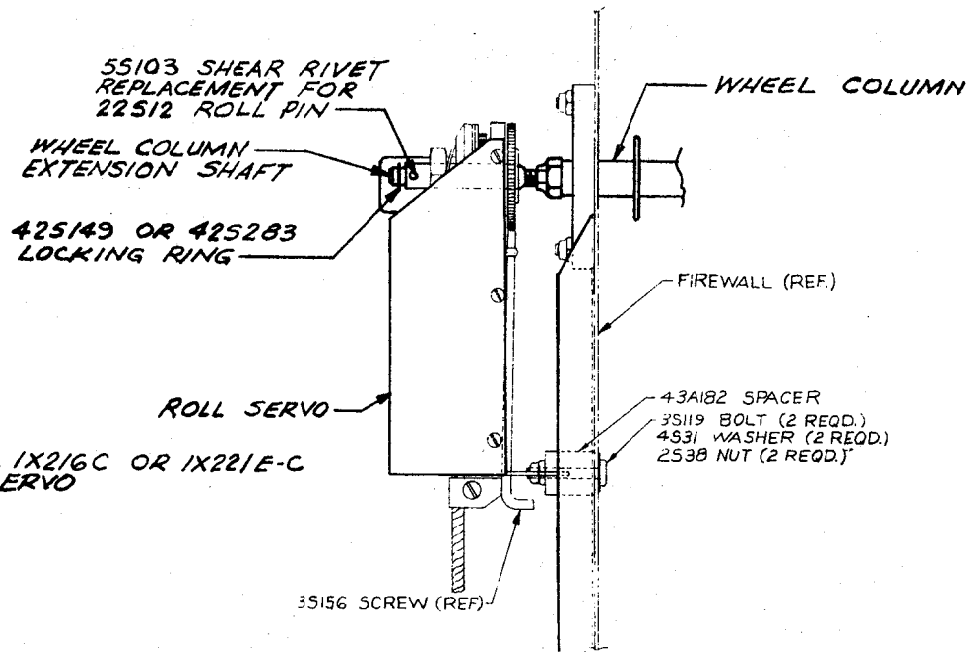

SIDE VIEW - PILOT'S SIDE
LOOKING INBOARD

ML-38 REFERENCE DRAWING of Typical President/Executive II/Autocontrol II/Altimatec II Roll Servo Installation. Exact Details Vary Slightly From Model to Model.