



SERVICE LETTER

No. 679

Piper Aircraft Corporation

Lock Haven, Pennsylvania, U.S.A.

January 21, 1974

Subject:

Fuselage Aft Bulkhead Inspection

Models Affected:

PA-30 Twin Comanche
PA-39 Twin Comanche C/R

Serial Numbers Affected:

30-1 to 30-2000 incl.
39-1 to 39-155 incl.

Compliance Time:

Recommended at the next regularly scheduled inspection interval, but not to exceed the next 100 hours of operation.

This inspection is to be repeated at each subsequent 100 hour inspection interval (in accordance with the appropriate Piper Standard Periodic Inspection Report) until the Fin Attachment Bracket Installation Kit, Piper Part No. 760 783 (see Material Required, below), is installed.

Purpose:

To provide instructions to inspect the fuselage aft bulkhead doubler at fuselage station 258.75 in the area of the aft fin attachment brackets for evidence of cracks and to provide material and instructions to reinforce this area (1) if cracks are detected or (2) to alleviate the repetitive inspection requirements as stated in Compliance Time, above.

Although this area is normally exposed to a visual inspection during the periodic inspection as specified by the Piper Standard Periodic Inspection Report forms for the above referenced aircraft, we are emphasizing the importance of proper and thorough inspection in this area.

The attached sketch/instruction sheet contains the necessary data required to perform the inspection.

Instructions:

1. Conduct inspection in accordance with the provisions of the attached sketch/instruction sheet.
2. If no cracks are detected in this area, no further action is required at this time (except continuing repetitive inspections until Kit 760 783 is installed); however, it is the owner's/operator's option whether to install the Fin Attachment Bracket Installation Kit, Piper Part No. 760 783, to relieve the repetitive inspection requirements referenced in Compliance Time, above.

(over)

Instructions: (continued)

3. If cracks are detected in this area, it will be necessary to install the Fin Attachment Bracket Installation Kit, Piper Part No. 760 783; installation instructions are contained in the kit.
4. Make appropriate log book entry.

Material Required:

One (1) each per aircraft Fin Attachment Bracket Installation Kit, Piper Part No. 760 783, at suggested unit retail price \$16.45A.

Availability of Parts:

Your Piper Dealer.

Effectivity Date:

This Service Letter is effective February 1, 1974.

Summary:

Please contact your Piper Dealer to make arrangements for compliance with the provisions of this service release in accordance with Compliance Time, above.

A Service Publication Compliance form is enclosed with copies of this service release mailed to affected owners of record; this form is to be filled out according to instructions on the form reverse side and left with the Piper Dealer performing the modification.

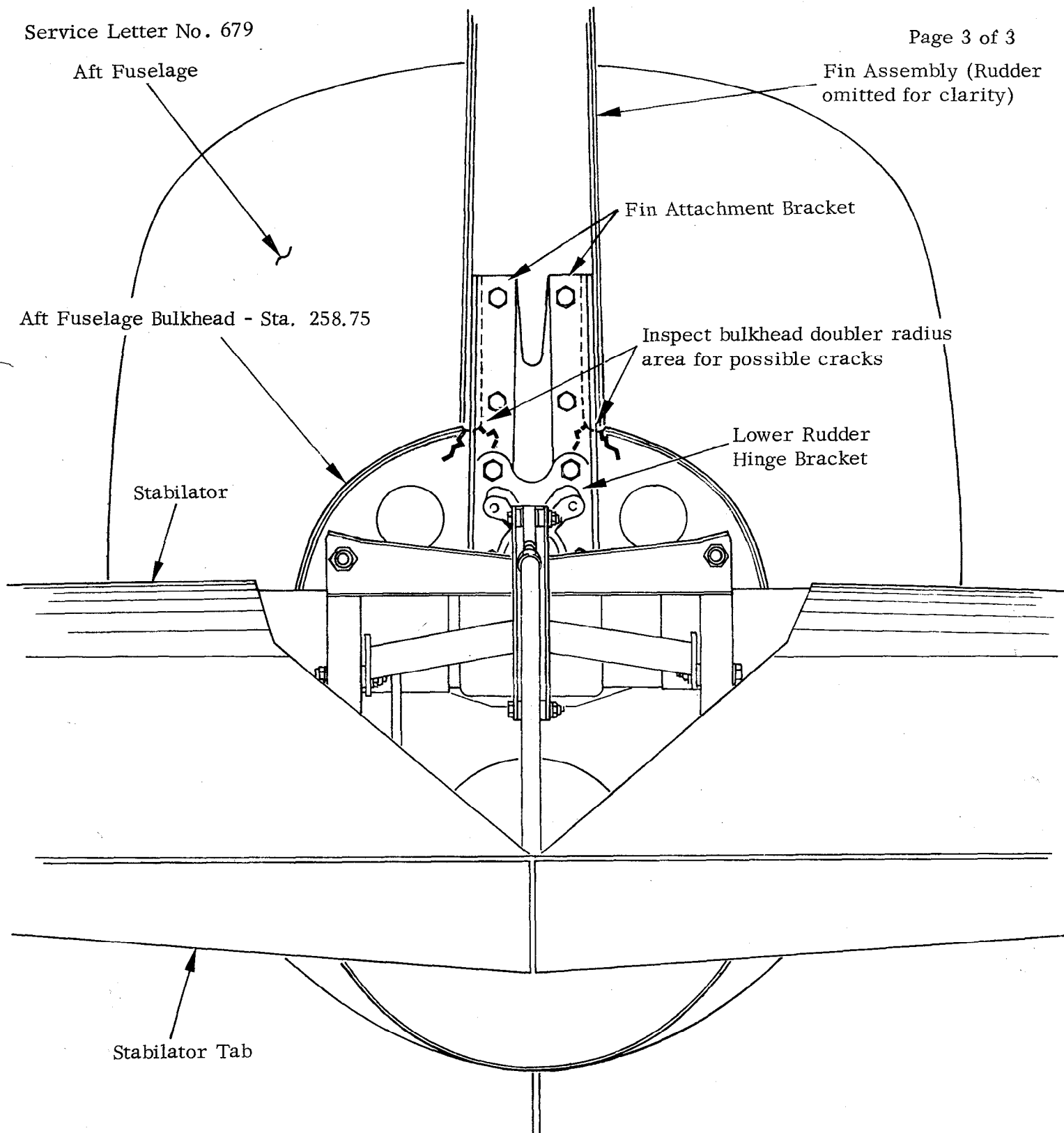

TYPICAL VIEW OF AFT FUSELAGE (LOOKING FORWARD)

INSTRUCTIONS

1. Remove tail cone fairing assembly from aft fuselage.
2. Carefully inspect bulkhead doubler on both sides of fin attachment brackets, as shown above, for evidence of cracks.
3. If cracks are detected, it will necessary to install the Fin Attachment Bracket Installation Kit P/N 760 783.
4. If cracks are not present, no further action is required at this time. (See Compliance Time.)
5. Reinstall tail cone fairing assembly.