



SERVICE LETTER

No. 751

Piper Aircraft Corporation

Lock Haven, Pennsylvania, U.S.A.

July 7, 1975 S

Subject:

Fin Front Spar Modification.

Models Affected:

PA-24-180, PA-24-250
and PA-24-260 Comanche
PA-24-400 Comanche

Serial Numbers Affected:

24-1 to 24-5047 Inclusive.
26-2 to 26-148 Inclusive.

Compliance Time:

At the owners/operators discretion.

Purpose:

Airworthiness Directive No. 75-12-06 requires a repetitive inspection of the fin front spar to fuselage attachment channel bend relief holes for evidence of cracks; repair or replace cracked channel/straps if cracks are detected, etc.

Currently, it is necessary to physically remove the fin to gain visual access to the channel relief holes, as the fin front spar extends over the relief holes by approximately 1/2 to 2/3 of the relief hole diameter.

To eliminate removal of the fin and to enable an easy visual inspection, the fin front spar may be modified in accordance with the sketch/instruction sheet contained on the reverse side of this release.

NOTE:

A.D. 75-12-06 refers to "channel part number 20749-0" and "straps part number 20749-5 and -6": these items are not listed in the PA-24 Parts Catalog, as they are components of Fuselage Bulkhead Assembly part number 20475-00 (PA-24-180 and 250), 20475-05 (PA-24-260) and 22904-00 (PA-24-400).

Instructions:

Refer to "Spar Trimming Detail" on reverse side of this release.

Material Required:

None.

5520

(over)

Availability of Parts:

Not applicable.

Effectivity Date:

This service release is effective upon receipt.

Summary:

Please contact your Piper field service facility to take advantage of this modification which will simplify the inspection requirements of A.D. 75-12-06.

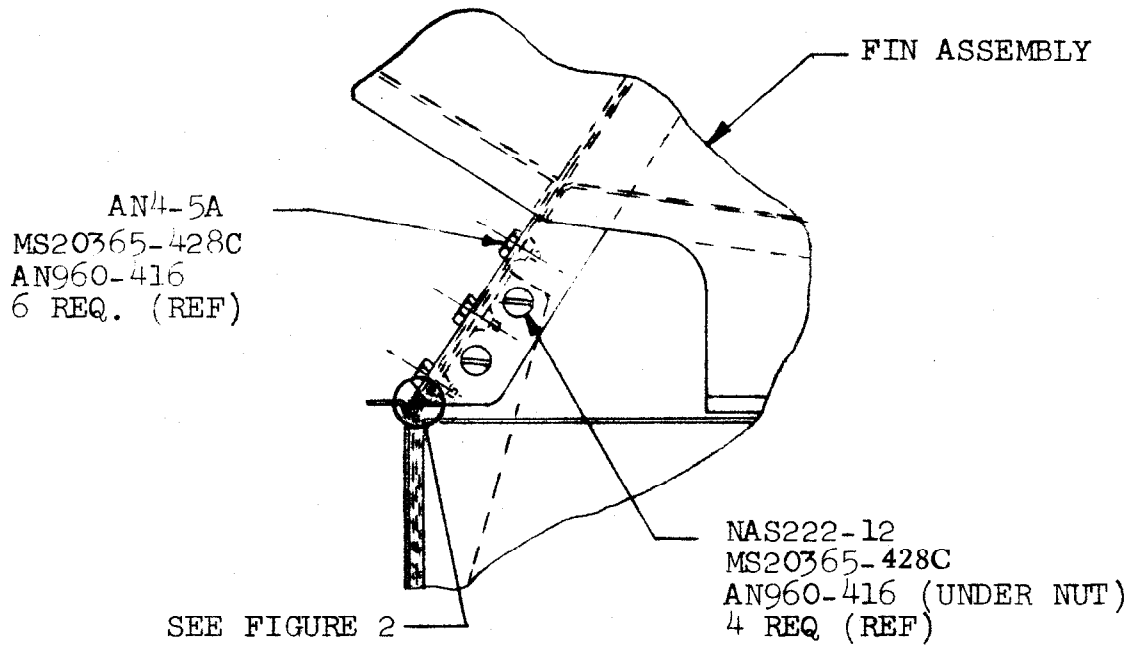

FIGURE 1

Hardware Identification (Above) :

<u>Spec</u>	<u>Item</u>	<u>Piper Part No.</u>
AN 4-5A	Bolt	400 002
AN 960-416	Washer	407 565
MS 20365-428C	Nut	404 888
NAS 222-12	Screw	411 231

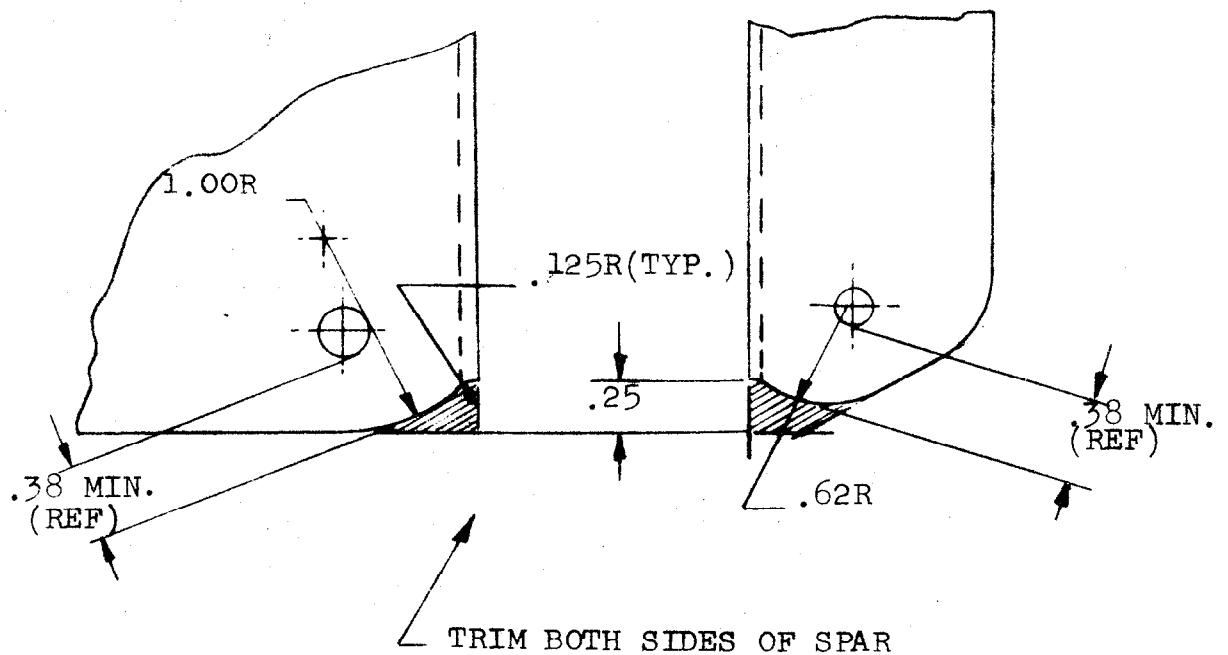

FIGURE 2

SPAR TRIMMING DETAIL