



# SERVICE LETTER

No. 653

Piper Aircraft Corporation

Lock Haven, Pennsylvania, U.S.A.

April 9, 1973

---

Subject:

Serrated Throttle Lever and Shaft -- reference attached Lycoming Service Instruction No. 1265, dated December 15, 1972.

Models and Serial Numbers  
Affected:

Refer to attached Lycoming Service Instruction No. 1265, Models Affected section.

Compliance Time:

Refer to attached Lycoming Service Instruction No. 1265, Time of Compliance.

Purpose:

To provide distribution of attached Lycoming Service Instruction No. 1265, dated December 15, 1972.

Balance of Service Letter format not applicable; refer to attached Lycoming Service Instruction No. 1265 for detailed information.

---

# AVCO LYCOMING DIVISION

WILLIAMSPORT, PENNSYLVANIA 17701

## Service Instruction



DATE: December 15, 1972

Service Instruction No. 1265  
Engineering Aspects are  
FAA (DEER) Approved

SUBJECT: Serrated Throttle Lever and Shaft

MODELS AFFECTED: Normally aspirated Avco Lycoming engines

TIME OF COMPLIANCE: As required; during carburetor overhaul.

All Marvel-Schebler carburetors are now being furnished and serviced with serrated throttle levers and shaft. The new components in the following list replace the old smooth shaft and throttle lever assemblies. They are adjustable 360° in increments of 15°.

The superceded lever was tightened on the shaft by

the clamping action of the attaching screw and secured with lock-wire. See fig. 1. The serrated feature of the new lever and shaft insures positive locking and eliminates the requirement for safety wire and torque requirements as specified in Service Bulletin No. 330A.

Below are listed the Marvel-Schebler Part Number changes; note that the Lycoming P/N's remain the same.

### THROTTLE LEVER AND SHAFT REPLACEMENT COMPONENTS

CARBURETOR PART NO. (LYC.)	THROTTLE LEVER PART NO.		THROTTLE SHAFT PART NO.		THROTTLE STOP PART NO.		THROTTLE SHAFT & STOP ARM, PART NO.		CARB. MODEL NO.
	NEW	OLD	NEW	OLD	NEW	OLD	NEW	OLD	
62289	12B-57	12A-17	13A-364	13-432	21-238	21-146	13-1520	13-949	MA-3-SPA
61547	12B-57	12A-17	13A-363	13-411	21-238	21-146	13-1519	13-1446	MA-3-A
62830	12B-57	12A-17	13A-364	13-432	21-238	21-146	13-1520	13-949	MA-3-SPA
69250	12B-57	12A-17	13A-365	13-452	21-238	21-146	13-1521	13-828	MA-4-SPA
72394	12B-57	12A-17	13A-365	13-452	21-238	21-146	13-1521	13-828	MA-4-SPA
71098	12B-58	12A-150	13A-366	13-440	21-239	21-154	13-1522	13-811	MA-4-5
71710	12B-58	12A-150	13A-366	13-440	21-239	21-154	13-1522	13-811	MA-4-5
72407	12B-59	12A-216	13A-366	13-440	21-239	21-154	13-1523	13-1182	MA-6AA
72920	12B-59	12A-216	13A-367	13A-221	21-239	21-154	13-1524	13-1315	MA-6AA
72740	12B-58	12A-150	13A-366	13-440	21-239	21-154	13-1523	13-1187	MA-4-5
74121	12B-58	12A-150	13A-366	13-440	21-239	21-154	13-1523	13-1182	MA-4-5
77158-Y	12B-55	12B-11	13A-368	13A-297	21-237	21-231	13-1526	13-1448	HA-6
77279	12B-57	12A-17	13A-365	13-452	21-238	21-146	13-1521	13-828	MA-4-SPA
77585	12B-57	12A-17	13A-363	13-411	21-238	21-146	13-1519	13-1446	MA-3-A
77888	12B-59	12A-216	13A-366	13-440	21-239	21-154	13-1523	13-1182	MA-6AA
77939	12B-57	12A-17	13A-364	13-432	21-238	21-146	13-1520	13-949	MA-3-PA
78728	12B-57	12A-17	13A-365	13-452	21-238	21-146	13-1521	13-828	MA-4-SPA
LW-10064	12B-58	12A-150	13A-366	13-440	21-239	21-154	13-1522	13-811	MA-4-5
LW-10196	12B-58	12A-150	13A-366	13-440	21-239	21-154	13-1523	13-1182	MA-4-5
LW-12175	12B-56	12B-22	13A-368	13A-297	21-237	21-231	13-1526	13-1448	HA-6
LW-10260	12B-56	12B-22	13A-368	13A-297	21-237	21-231	13-1526	13-1448	HA-6
LW-10619	12B-57	12A-17	13A-364	13-432	21-238	21-146	13-1520	13-949	MA-3-PA
LW-10540	12B-58	12A-150	13A-366	13-430	21-239	21-154	13-1523	13-1182	MA-4-5
LW-11222	12B-57	12A-17	13A-365	13-452	21-238	21-146	13-1521	13-828	MA-4-SPA
69540	12B-59	12A-216	13A-366	13-440	21-239	21-154	13-1523	13-1182	MA-4-5
73257	12B-58	12A-150	13A-366	13-440	21-239	21-154	13-1523	13-1182	MA-4-5AA
72386	12B-59	12A-216	13A-366	13-440	21-239	21-154	13-1523	13-1182	MA-4-5
73381			13A-366	13-440	21-239	21-154	13-1525	13-435	MA-6AA

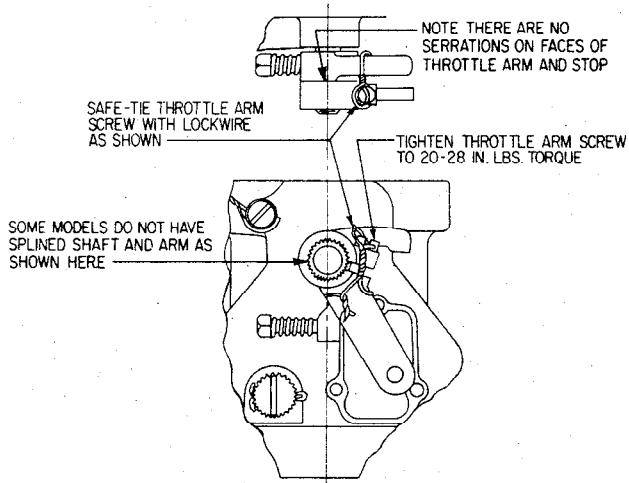

Figure 1. Previous Throttle Arm Configuration Showing Clamping Screw and Lockwire

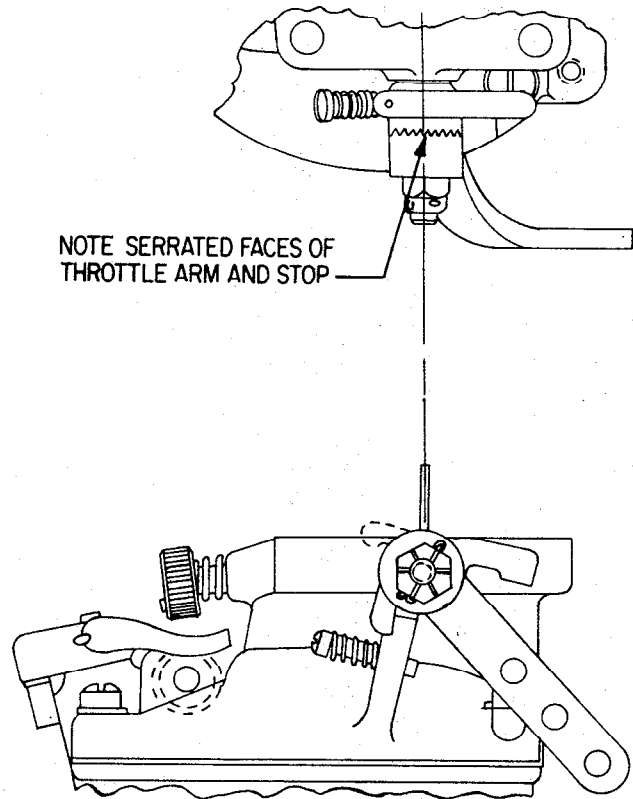

Figure 2. New Throttle Arm Configuration Showing Serrated Faces of Arm and Stop Levers