



SERVICE LETTER

No. 650

Piper Aircraft Corporation

Lock Haven, Pennsylvania, U.S.A.
September 27, 1973 S/M

Subject:

Inspection of Landing Gear Retraction and Flap Control Transmission Assemblies

Models Affected:

PA-24-180, PA-24-250 and
PA-24-260 Comanche
PA-24-400 Comanche
PA-30 Twin Comanche
PA-39 Twin Comanche C/R

Serial Numbers Affected:

24-1 to 24-5047 incl.
26-2 to 26-148 incl.
30-1 to 30-2000 incl.
39-1 to 39-156 incl.

Compliance Time:

Recommended within the next 100 hours of operation.

Purpose:

- I. A few reports have been received from the field describing landing gear retraction and/or flap malfunctions due to failure of the transmission assemblies to operate properly. This occurred as a result of the transmission sleeve turning on the threaded transmission shaft, due to the fact that the sleeve was not properly staked to the transmission body.
 - A. This affects only aircraft referenced above that have had Piper Part Nos. 21763-02, 489 375, 489 377, 25720-02 or 25720-04 transmission assemblies installed in the field; aircraft referenced above with original production transmission assemblies installed are not affected.
 - B. Flap control transmissions were not installed in PA-24-180 aircraft and were not installed in PA-24-250 aircraft until Serial No. 24-2844 and up.

This service release provides instructions to inspect landing gear retraction and/or flap control transmission assemblies on the above referenced aircraft that have had transmission assemblies replaced in the field, to insure that the transmission sleeve was properly staked to the transmission body (refer to attached sketch/instruction sheet for proper staking instructions).

- II. Further, we have been advised by one of our suppliers that a certain group of transmissions were manufactured from incorrect material. The affected group of these transmissions is identified immediately below and must be replaced.

Purpose: (continued)

- A. Landing Gear Transmission Assemblies -- Piper Part Nos. 25720-00, -02, and -03, manufactured by Dukes Astronautics Company, manufacturer's part number 4260-00, Piper Code No. 489 383, manufacturer's serial numbers 919 through 1068 inclusive.

Instructions:

1. Refers to Purpose I; attached sketch/instruction sheet contains transmission staking instructions.
2. Refers to Purpose II; gain access to the landing gear retraction transmission assembly and check manufacturer's identification plate in accordance with paragraph A under Purpose II, above. Replace transmission if the existing transmission is within the manufacturer's serial numbers listed above.

Material Required:

One (1) each Landing Gear Retraction Transmission Assembly, if required per Instructions No. 2, above; refer to appropriate Piper parts catalog for proper material identification.

Availability of Parts:

Your Piper Dealer.

Effectivity Date:

This Service Letter is effective October 15, 1973.

Summary:

Please contact your Piper Dealer to make arrangements for compliance with this Service Letter in accordance with the provisions of Compliance Time, above. Material required for this modification in accordance with Instructions No. 2, above, is available free of charge through your Piper Dealer, providing the modification is accomplished by a Piper Dealer.

A Service Publication Compliance Form is enclosed with each copy of this Service Letter mailed to affected owners/operators of record. Following compliance with this Service Letter, please fill out the form according to the instructions on the reverse side of the form bottom copy and leave the form with your Piper Dealer.

Flap Control Transmission Assembly

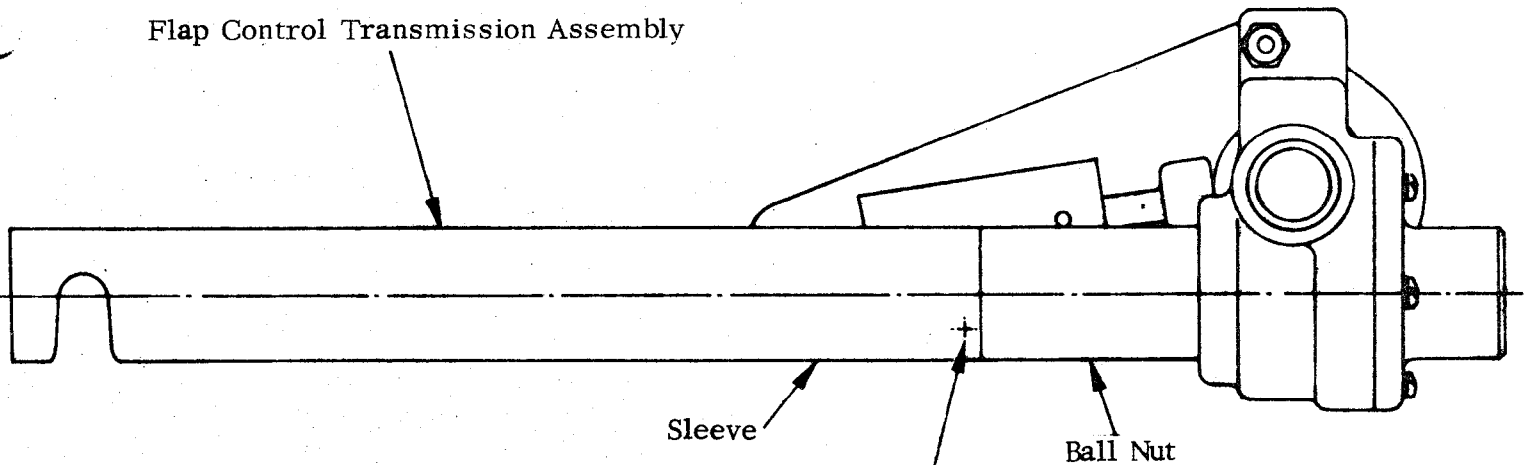

Sleeve

Ball Nut

Sleeve must be staked at three points
(on circumference of sleeve) to prevent
separation of threaded joint.

Landing Gear Retraction Transmission Assembly

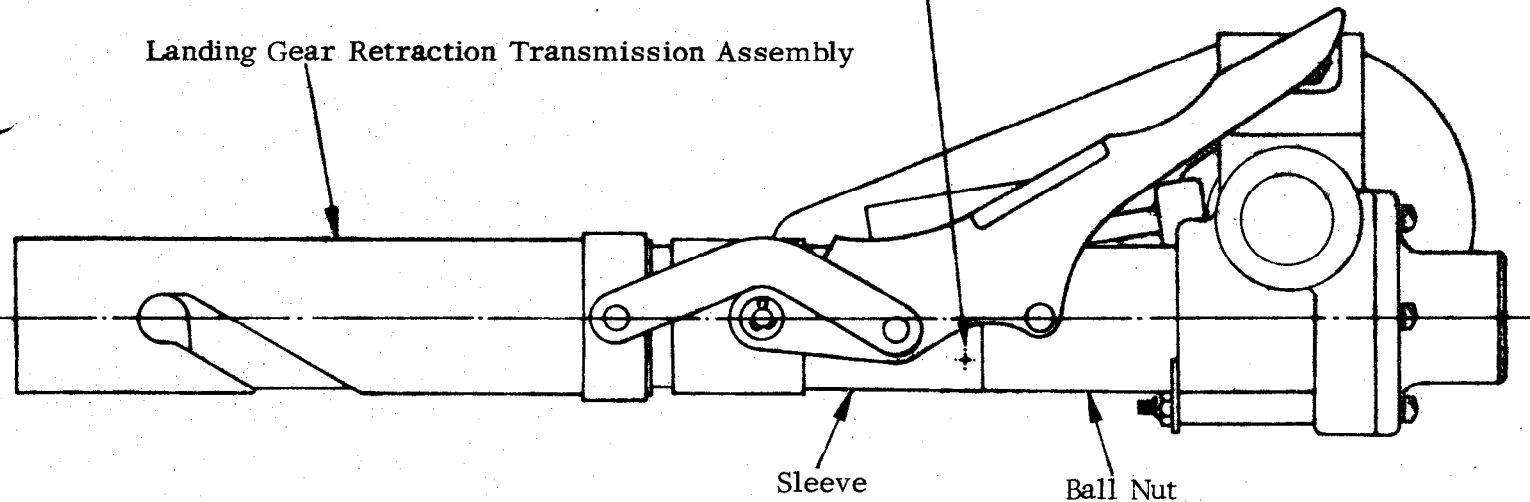

Sleeve

Ball Nut

● INSTRUCTIONS

1. Refer to the appropriate Service Manual and gain access to the flap control transmission (if installed) and the landing gear retraction transmission.
2. Inspect transmissions to determine if sleeve has been properly staked as shown on above sketch.
3. If the transmission sleeves have been properly staked, no further action is required.
4. If either of the transmission sleeves have not been staked, it will be necessary to remove the transmission from the airplane and stake as shown (sleeve must be tight against ball nut before staking). Use a center punch and carefully stake to a depth of .030 to .040 inches. Refer to the appropriate Service Manual for proper Removal and Installation Procedures.

SUBJECT: Identification of Serviceable/Non-Serviceable Landing Gear Retraction and Flap Control Transmission Ball Screws

Referring to Purpose II, Piper Service Letter No. 650 dated September 27, 1973, a group of landing gear retraction transmission assemblies was to have been replaced for reasons specified therein. The effectivity of this action encompassed Landing Gear Transmission Assemblies, Piper Part Nos. 25720-00, -02, and -03, manufacturer's serial nos. 919 through 1068 incl.

Subsequent to publication of Piper Service Letter No. 650, it has been determined that not all of the above referenced transmission assemblies require replacement. An inspection procedure has been provided by the manufacturer to determine if the transmissions referred to above need to be replaced. Details are specified below and on the sketch on the reverse side of this communication.

1. Expose the threaded ball screw portion of the transmission assembly to view.
2. With a magnifying glass, inspect the threads as specified on the sketch on the reverse side of this communication.
3. Refer to the "detailed" call-outs on the sketch to determine whether the transmission assembly must be replaced.
4. Refer to the balance of Piper Service Letter No. 650 for replacement material identification data.

NOTE 1: This addendum is to be attached to and become an integral part of Piper Service Letter No. 650, dated September 27, 1973.

NOTE 2: A copy of this addendum is being mailed direct to affected owners/operators.

- REFERENCE SERVICE LETTER NO. 650: Purpose II
Identification of Transmission Ball Screw;
Transmission serial numbers 919 thru 1068 inclusive.

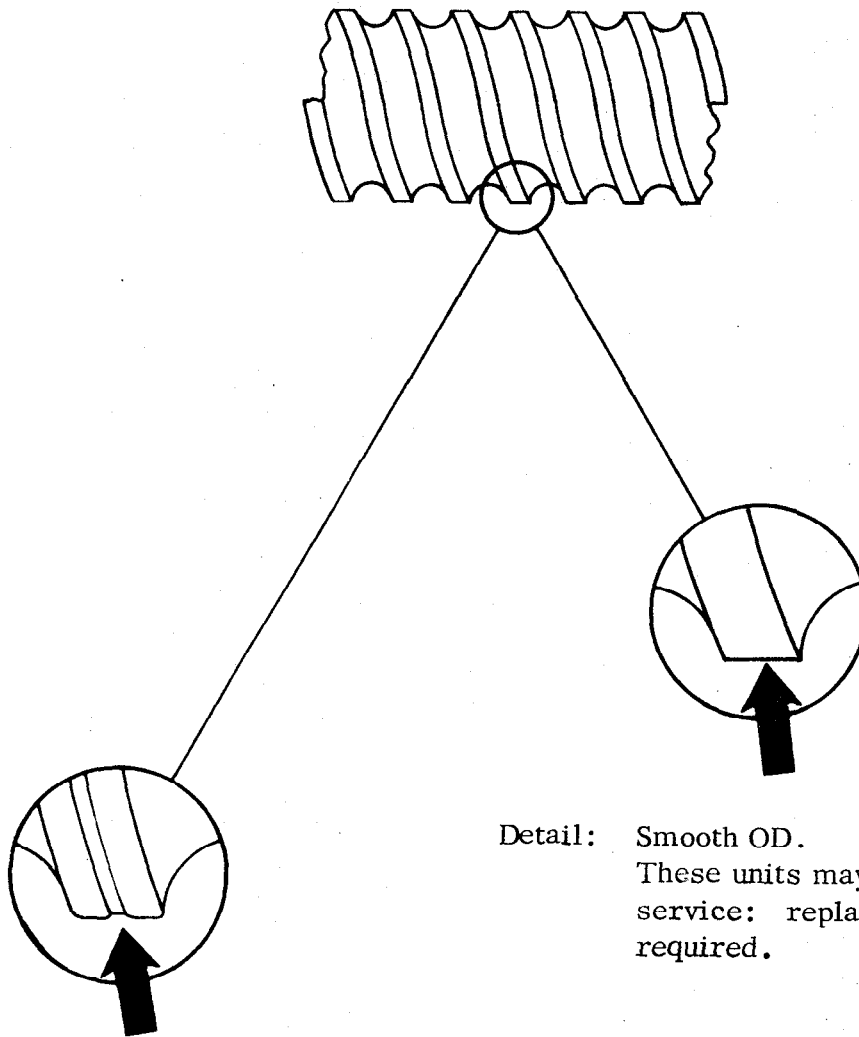

Detail: Grooved OD.
These units must be replaced.

Detail: Smooth OD.
These units may remain in
service: replacement not
required.