

SERVICE



LETTER

Service Letter No. 477

May 18, 1966

TO: Distributors, Dealers, Certified Service Centers and Owners

SUBJECT: F.A.A. Airworthiness Directive No. 66-12-2 issued May 3, 1966 (temporary revision to airspeed limits)

MODELS AFFECTED: PA-30 Twin Comanches, Serial Nos. 30-1 to 30-852 incl., 30-854 to 30-901 incl.

F.A.A. Airworthiness Directive No. 66-12-2 issued May 3, 1966 indicated effectivity of all PA-30 Twin Comanche aircraft. It has been substantiated that Twin Comanches indicated by the above serial numbers are not affected by the subject Airworthiness Directive, and an amendment to this directive will be issued.

NOTE

If during the service life of the airplane alterations or repairs were made to the stabilator or the stabilator trim tab the stabilator must be rebalanced immediately in accordance with the instructions and sketch attached to this letter.

Aircraft that have had stabilator de-icer boots installed and did not change the stabilator balance after the installation of the de-icer boots are not required to have the stabilator rebalanced.

PIPER AIRCRAFT CORPORATION, LOCK HAVEN, PA., U. S. A.

MODEL PA-30

PROCEDURE FOR BALANCING THE STABILATOR

- a. Whenever a stabilator has been repaired, it must be balanced before being flown.
- b. Stabilator installation must be complete before balancing, including tabs and paint. Stabilator control cables must be disconnected from stabilator balance arm and tab actuator arm must be disconnected from stabilator tab horn during balancing. Hardware used to connect the extension spring cable and stabilator control cables should be removed. Hardware holding balance arm weight in place should be installed. A small piece of tape should be used to hold tabs neutral with stabilator. It is very important to have the stabilator free to rotate with a minimum of frictional resistance.

NOTE

If the bearing resistance is more than light, the nuts of the bolts holding the stabilator torque horn to the stabilator torque tube, the nuts of the bolts holding the stabilator to the torque tube and the nuts of the bolts holding the stabilator stop to the torque tube should be loosened and the bearing resistance measured again. When this is done, the nuts must be tightened just enough to take the play out of the washers.

- c. Master check weight 23584-00 (weight 1.58 pounds) should be placed on top of balance weight 23594-00 with the side marked "FRONT" facing forward. If this is not enough weight to obtain static balance with the balance arm level, plates 23179-00 must be added to the forward balance weight attachment bolt until 100% static balance is obtained or until up to two plates more than that required for **balance** have been added. It should never be necessary to use more than eight plates. If a total of more than eight plates is necessary to obtain balance, the manufacturer should be consulted.
- d. If it should become necessary in the field to balance a stabilator without a master check weight, a temporary balancing can be accomplished by following the procedure given in "b" above except that instead of using a master check weight a sensitive and accurate fish scale can be used to get a balance with 49 ± 3 inch pounds of torque. Thus plates should be added (up to eight) until a lifting force of between 2.71 and 2.88 pounds will balance the stabilator with the fish scale being hooked to the bolt which fastens the two stabilator-connecting tabs together (arm of 17 inches). As soon as a master check weight is available the balance should be checked for accuracy.
- e. After balancing is accomplished, the check weight (or fish scale) should be removed and the plates should be distributed equally on both sides of the stabilator balance tube and the bolt secured.
- f. All stabilator and tab controls should be reconnected.
- g. The stabilator control extension spring link should be adjusted to obtain 1-1/4 inch extension of the spring with the stabilator stops adjusted and the control wheel in the full forward position.
- h. The operation and feel of the stabilator controls should then be checked for proper movement.

(over)

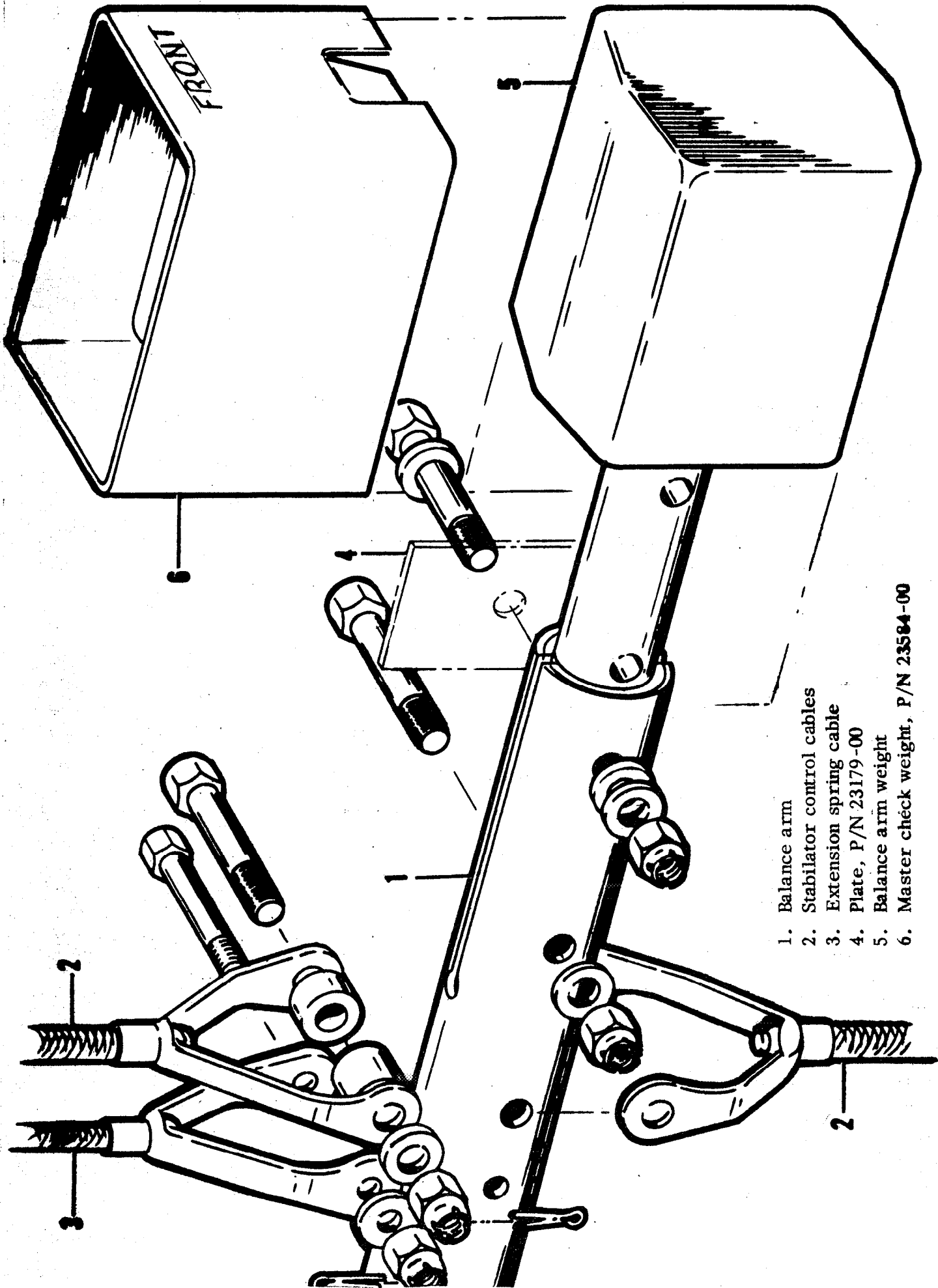

1. Balance arm
2. Stabilator control cables
3. Extension spring cable
4. Plate, P/N 23179-00
5. Balance arm weight
6. Master check weight, P/N 23564-00