



**PIPER**  
**COMANCHE**  
**OWNER'S HANDBOOK**

## **WARNING**

The rudder pedals are suspended from a torque tube which extends across the fuselage. The pilot should become familiar with the proper positioning of his feet on the rudder pedals so as to avoid interference with the torque tube when moving the rudder pedals or operating the toe brakes.

757 436

# COMANCHE

PA-24-180 PA-24-250

## Owner's Handbook



**Piper Aircraft Corporation, Lock Haven, Pa.  
U. S. A.**

## NOTICE

THIS HANDBOOK IS NOT DESIGNED, NOR CAN ANY HANDBOOK SERVE, AS A SUBSTITUTE FOR ADEQUATE AND COMPETENT FLIGHT INSTRUCTION, OR KNOWLEDGE OF THE CURRENT AIRWORTHINESS DIRECTIVES, THE APPLICABLE FEDERAL AIR REGULATIONS, AND ADVISORY CIRCULARS. IT IS NOT INTENDED TO BE A GUIDE OF BASIC FLIGHT INSTRUCTION, NOR A TRAINING MANUAL.

THE HANDBOOK IS DESIGNED:

1. TO HELP YOU OPERATE YOUR COMANCHE WITH SAFETY AND CONFIDENCE.
2. TO MORE FULLY ACQUAINT YOU WITH THE BASIC PERFORMANCE AND HANDLING CHARACTERISTICS OF THE AIRPLANE.
3. TO MORE FULLY EXPLAIN YOUR COMANCHE'S OPERATION THAN IS PERMISSIBLE TO SET FORTH IN THE AIRPLANE FLIGHT MANUAL.

IF THERE IS ANY INCONSISTENCY BETWEEN THIS HANDBOOK AND THE AIRPLANE FLIGHT MANUAL APPROVED BY THE F.A.A., THE AIRPLANE FLIGHT MANUAL SHALL GOVERN.

---

Revised text and illustrations shall be indicated by a black vertical line in the margin opposite the change. A line opposite the page number will indicate that material was relocated.

Additional copies of this manual, Piper No. 753 570, may be obtained from your Piper Dealer.

---

Published by  
PUBLICATIONS DEPARTMENT  
Piper Aircraft Corporation  
753 570  
Issued: July 1961  
Revised: February 1974

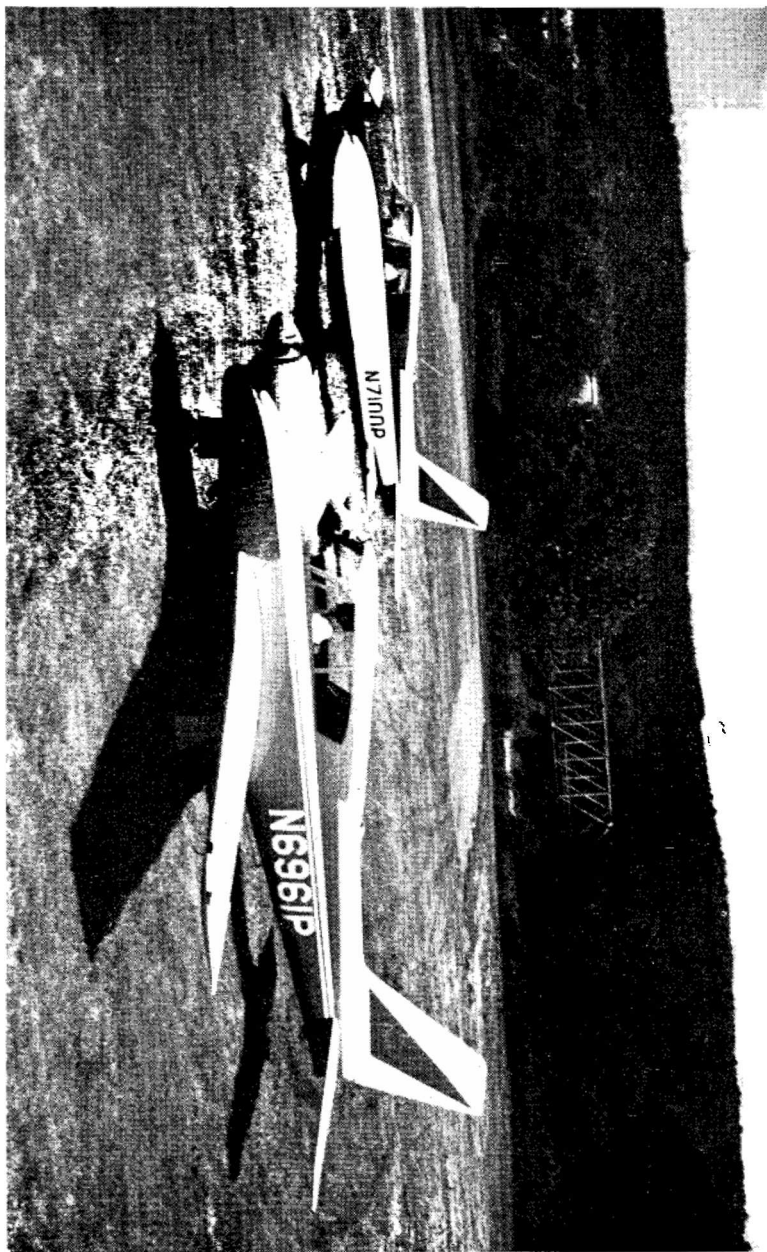

## **SECTION ONE**

<b>DESIGN FEATURES</b>	<b>Page</b>
<b>I. Specifications</b> . . . . .	<b>5</b>
<b>II. Engine and Propeller</b> . . . . .	<b>6</b>
<b>III. Fuselage and Wing Structures</b> . . . . .	<b>7</b>
<b>IV. Landing Gear</b> . . . . .	<b>8</b>
<b>V. Control System and Surfaces</b> . . . . .	<b>11</b>
<b>VI. Fuel System</b> . . . . .	<b>12</b>
<b>VII. Electrical System</b> . . . . .	<b>15</b>
<b>VIII. Cabin Features</b> . . . . .	<b>15</b>

## DESIGN FEATURES

## 1. Specifications:

	PA-24 180	PA-24 250
Engine .....	Lyc. O-360-A	Lyc. O-540-A1A5
HP and RPM .....	180 at 2700	250 at 2575
Gross Weight (Lbs.) .....	2550	2900
Empty Weight (Standard) (Lbs.) .....	1510	1630
Useful Load (Lbs.) .....	1040	1270
Empty Weight (Custom) (Lbs.) .....	1550	1670
Useful Load (Custom) (Lbs.) .....	1000	1230
Empty Weight (Super Custom) (Lbs.) .....	1575	1720
Useful Load (Super Custom) (Lbs.) .....	980	1180
Wing Span (Ft.) .....	36	36
Wing Area (Sq. Ft.) .....	178	178
Length (Ft.) .....	24.7	24.9
Height (Ft.) .....	7.3	7.3
Propeller Diam. (Max. In.) .....	74	77
Power Loading (Lbs. per HP) .....	14.2	11.2
Wing Loading (Lbs. per Sq. Ft.) .....	14.3	15.7
Baggage Capacity .....	200	200
Fuel Capacity (Standard, Gals.) .....	50	60
Fuel Capacity (With Reserve Fuel, Gals.) .....	60	90
Tire Pressure (Lbs.) .....	Nose 27, Main 27	Nose 27, Main 42
Wheel Base (Ft.) .....	6.5	6.5
Wheel Tread (Ft.) .....	9.8	9.8
Top Speed (MPH) .....	167	190
Cruising Speed		
(75% Power, Sea Level, MPH) .....	150	171
Optimum Cruising Speed		
(75% Power, Optimum Alt.) .....	160	181
Stalling Speed (Flaps Down, MPH) .....	61	65
Take-off Run (Ft.) .....	750	1000
Landing Roll (Flaps Down, Ft.) .....	600	650
Best Rate of Climb Speed (MPH) .....	95	95
Rate of Climb (Ft. per Min.) .....	910	1350
Service Ceiling (Ft.) .....	18,500	20,000
Absolute Ceiling (Ft.) .....	21,000	22,000
Fuel Consumption		
(Gal. per Hr., 75% Power) .....	10	14
Cruising Range		
(75%, Sea Level, Std. Fuel) .....	5 Hrs., 750 Mi.	4.3 Hrs., 740 Mi.
Cruising Range, Optimum (Std. Fuel) .....	6.2 Hrs., 920 Mi.	7.5 Hrs., 1100 Mi.
Cruising Range		
(75%, Sea Level, Reserve Fuel) .....	6 Hrs., 900 Mi.	6.4 Hrs., 1100 Mi.
Cruising Range, Optimum (Reserve Fuel) .....	7.5 Hrs., 1100 Mi.	11.2 Hrs., 1650 Mi.

Performance figures are for Custom airplanes flown at gross weight under standard conditions at sea level, or stated altitude. Any deviation from Custom equipment may result in changes in performance.

## II. Engine and Propeller:

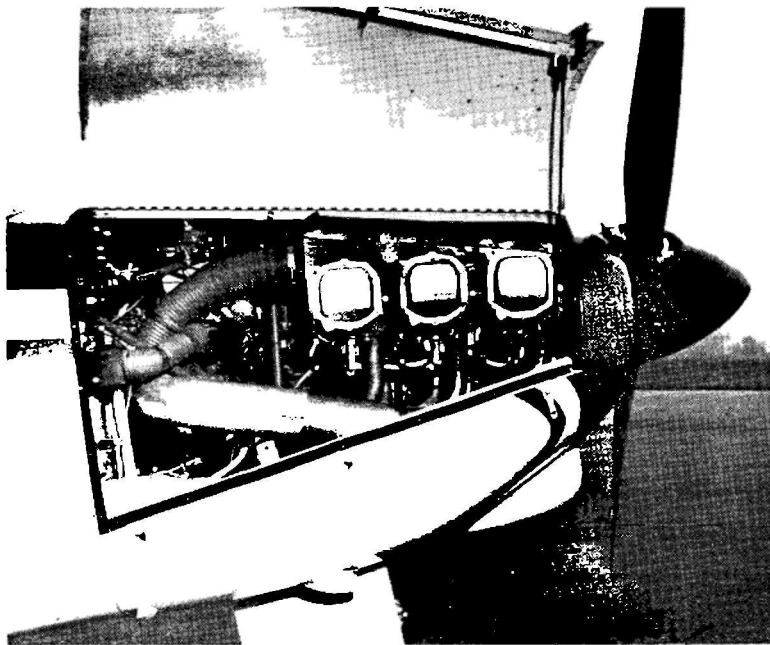

The Comanche Model 180 is equipped with a Lycoming O-360-A series engine rated at 180 HP at 2700 RPM. The engine in the 250 is a Lycoming O-540-A series, developing 250 HP at 2575 RPM. Both engines have compression ratios of 8.5 to 1, and require 91/96 octane minimum fuel. They are furnished with a geared starter, 50 ampere 12-volt generator, voltage regulator, shielding, fuel pump, propeller governor, vacuum pump drive, and carburetor air box and filter.

The exhaust system on the 180 and 250 is a stainless steel cross over type. A large muffler and oversize heater shroud is provided on both the 180 and 250 installations, to supply heat for cabin and carburetor heater systems.

Engine cooling is accomplished without the complication of cowl flaps or exhaust augmenters, and without drag producing fixed cowl flanges.



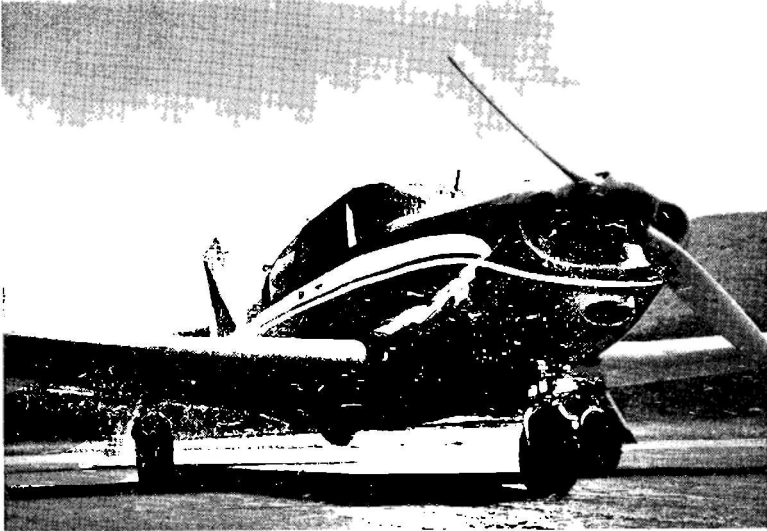

The 180 uses the Hartzell, model HC92ZK8D.

The 250 uses the Hartzell, model HC82NK1D. All propellers are constant speed controllable.

### III. Fuselage and Wing Structures:

Structures are of sheet aluminum construction, and are designed to ultimate load factors well in excess of normal requirements. All components are completely zinc chromate primed, exterior surfaces are enameled as well.

The main spars of the wings are joined with high strength butt fittings in the center of the fuselage, making in effect a continuous main spar. Main spars are attached to the fuselage at the side of the fuselage and in the center of the structure; wings are attached also at the rear spar and at an auxiliary front spar.

The wing airfoil section is a laminar flow type, NACA642A215, with maximum thickness about 40% aft of the leading edge. This permits the main spar, located at the point of maximum thickness, to pass through the cabin under the rear seat, providing unobstructed cabin floor space ahead of the rear seat.

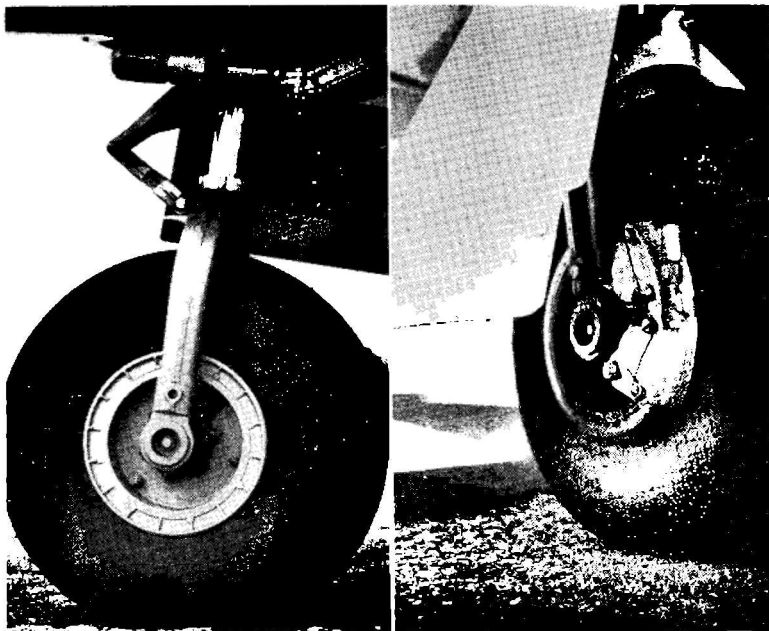

#### IV. Landing Gear:

The main wheels are Cleveland Aircraft Products Model 3070, 600 x 6, with single disc hydraulic brakes. Model 3000-250. The nose wheel is Cleveland Model 38501: all wheels have 600 x 6 tires.

The nose gear is steerable through a 40 degree arc through use of the rudder pedals. As the nose gear retracts, the steering linkage disengages to reduce rudder pedal loads in flight. The nose wheel is equipped with a hydraulic shimmy damper.

Many of the parts of the three air-oil type landing gear units, including the forks, struts, and torque links, are interchangeable. All three gears are inflated to approximately  $2\frac{3}{4}$  inches of strut extension.

The landing gear is retracted or extended in 7 seconds by an electric motor installed under the front center floorboards, actuating push-pull controls to each of the gears. Manual extension of the

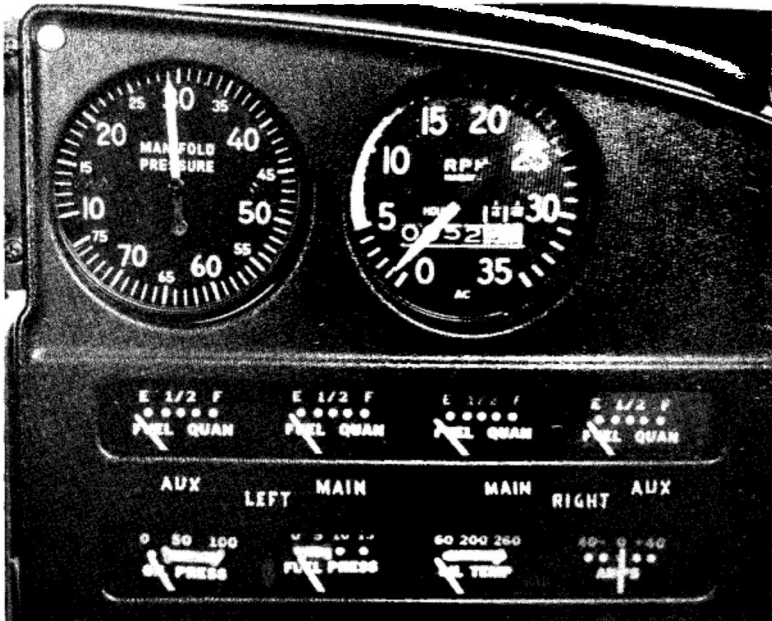
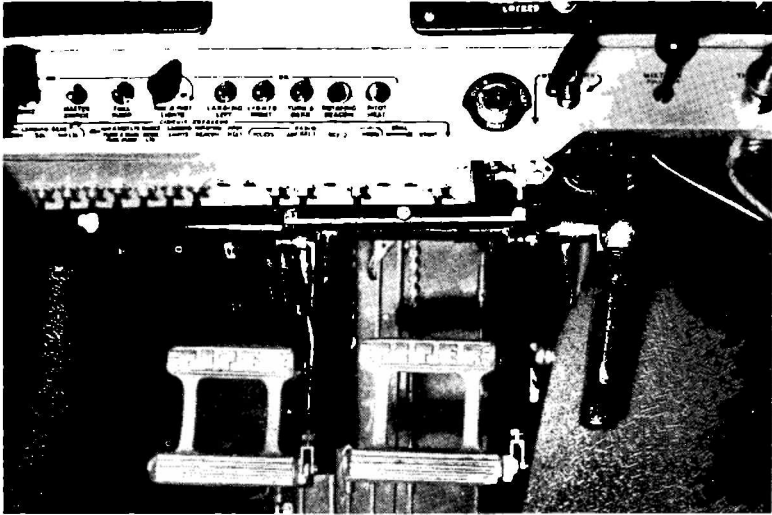

gear is accomplished with the Emergency Gear Lever aft of the nose gear well.

The brakes are actuated by toe brake pedals mounted on the left set of rudder pedals or by a hand lever protruding from under the instrument panel. Hydraulic brake cylinders are located above the left rudder pedals and are accessible in the cockpit for servicing. Parking brake valves are incorporated in each cylinder. Two cables extending from the parking brake "T" handle are attached to the parking brake valves. To prevent inadvertent application of the parking brake in flight, a safety lock is incorporated in the valves, thus eliminating the possibility of pulling out the "T" handle until pressure is applied by use of the toe brakes or the hand lever. The brake fluid reservoir is installed on the front left side of the firewall.

To prevent inadvertent retraction of gear on the ground, a switch is installed on the left main gear which cuts off current to the re-

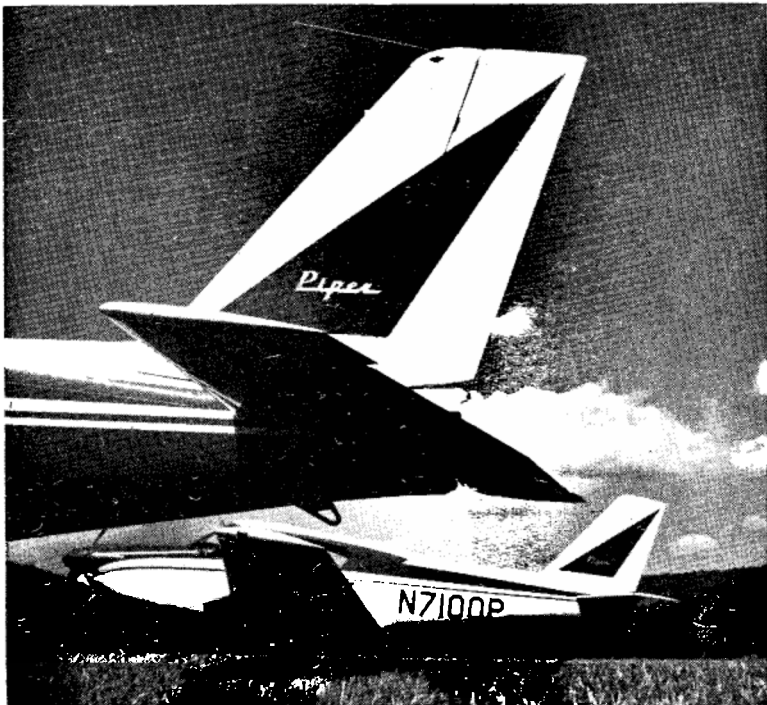

traction motor until the gear is fully extended. This feature must not be tested during ground operation.

A green light on the instrument panel below the landing gear switch indicates all gears down and locked. An amber light above the switch indicates gears up. These lights are automatically dimmed when the navigation lights are turned on.

## **V. Control System and Surfaces:**

Dual wheel and rudder controls are provided, with cables to control surfaces. The horizontal tail is a stabilator, with an anti-servo tab which also acts as a longitudinal trim tab, actuated with trim crank in the cabin ceiling. The stabilator provides extra stability and controllability with less size, drag and weight than with conventional horizontal tail surfaces.

A rudder trim adjustment is mounted on the right side of the nose wheel dome to permit directional trim as needed in flight.

The flaps are manually operated, balanced for light operating forces and spring loaded to return to the up position. Locks on the



inboard ends of the flaps hold them in the up position so that the right flap can be stepped on for entry or exit. The flap will not support a step load except when in the full up position, so must be completely retracted when used as a step.

The flaps have three extended positions, 9, 18 and 27 degrees. Full flap is recommended for landing, zero or partial flap for take-offs.

## VI. Fuel System:



Two rubber like fuel cells in the inboard leading edge sections of the wings provide fuel capacity. Available as optional equipment on the PA-21-250 only are two auxiliary fuel cells located outboard of the main fuel cells. Auxiliary fuel cells have a 15 gallon capacity. The cells should be kept full of fuel during storage of the airplane to prevent accumulation of

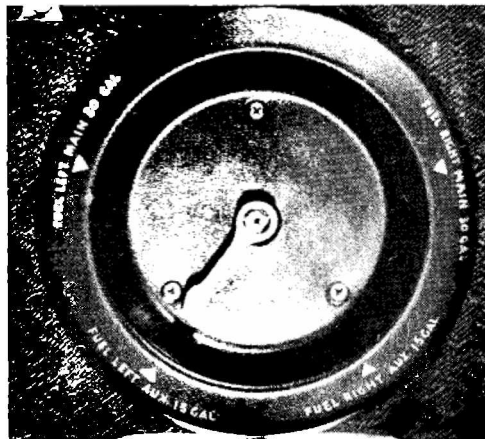

moisture and deterioration of the cells. For long term storage without fuel, the cells should be coated with light engine oil to keep the rubber from drying out.

The main fuel cells hold a maximum of 30 gallons. On the 180, to obtain the standard fuel quantity of 50 gallons total, or 25 gallons per tank, the cells are filled only to the bottom of the filler neck, which extends into the fuel cell about one inch. To obtain the standard plus reserve quantity, the cells are filled to the top of the filler necks. This system provides a reserve fuel capacity for the 180 without the necessity for extra tanks.

On the 250 Comanche, 60 gallons is the standard fuel capacity, however if auxiliary fuel cells are installed the fuel capacity is increased to 90 gallons.

An electric auxiliary fuel pump is provided for use in the event (two electric auxiliary fuel pumps on PA-24-250) of failure of the standard engine driven pump. The electric pump is normally turned on for landings and take-offs.

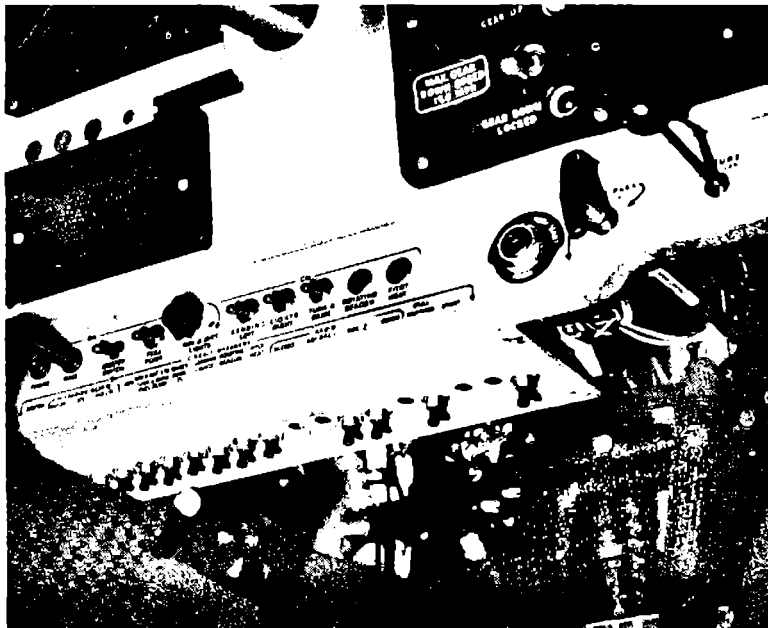

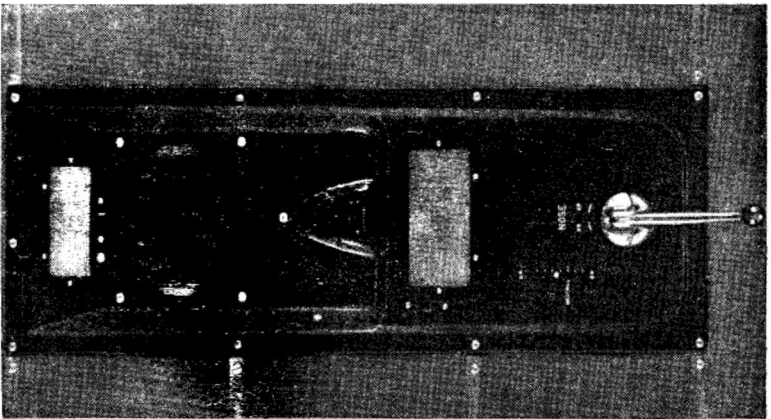
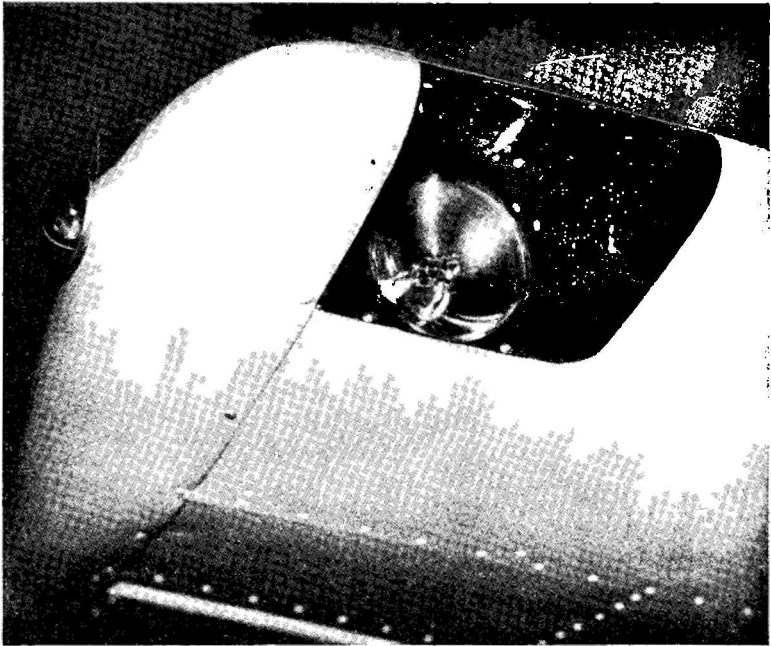



The fuel strainer, equipped with a quick drain, is mounted under the right forward section of the fuselage. Draining of the strainer is accomplished in the cockpit by opening the hinged access door located in the floorboard just aft of the fuel selector valve and moving the quick drain valve handle to the full aft position. The strainer should be drained regularly to check for water or dirt accumulations.

The procedure for draining the tanks and lines is to open the gasculator quick drain for a few seconds with the fuel tank selector on one tank. Then change the fuel selector to the opposite tank and repeat the process, (the same process applies to the auxiliary tanks), allowing enough fuel to flow out to clear the line as well as the gasculator.

## **VII. Electrical System:**

A 12-volt 33 ampere hour battery is mounted behind the baggage compartment in a sealed stainless steel battery box. The standard generator has an output of 50 amperes.

Electrical switches and circuit breakers, located on the lower left instrument panel, control the navigation and instrument lights, two landing lights, electric turn and bank, and other electrical components. The circuit breakers automatically break the electrical circuit if an overload is applied to the system, preventing damage to electrical wiring. To reset the breakers, simply push in the buttons. Allow approximately two minutes for breakers to cool before resetting. Continual popping out of a circuit breaker indicates trouble in the electrical system and should be investigated. Circuit breakers can be manually tripped by pulling its button to isolate or determine the source of trouble.

## **VIII. Cabin Features:**

The instrument panel of the Comanche is designed to accommodate the customary advanced flight instruments on the left side in front of the pilot, and the engine instruments on the right side. Provision for extra instruments is made in both sections. Instruments are shock mounted, and are accessible for maintenance by removing a portion of the fuselage cowl over the instruments.

The Artificial Horizon and the Directional Gyro in the flight group are vacuum operated through use of a vacuum pump installed

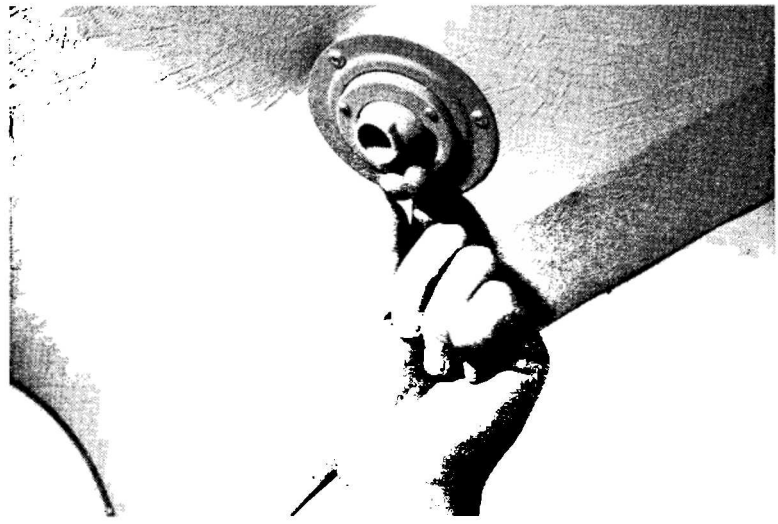

**Ventilating and Heating  
Comanche**

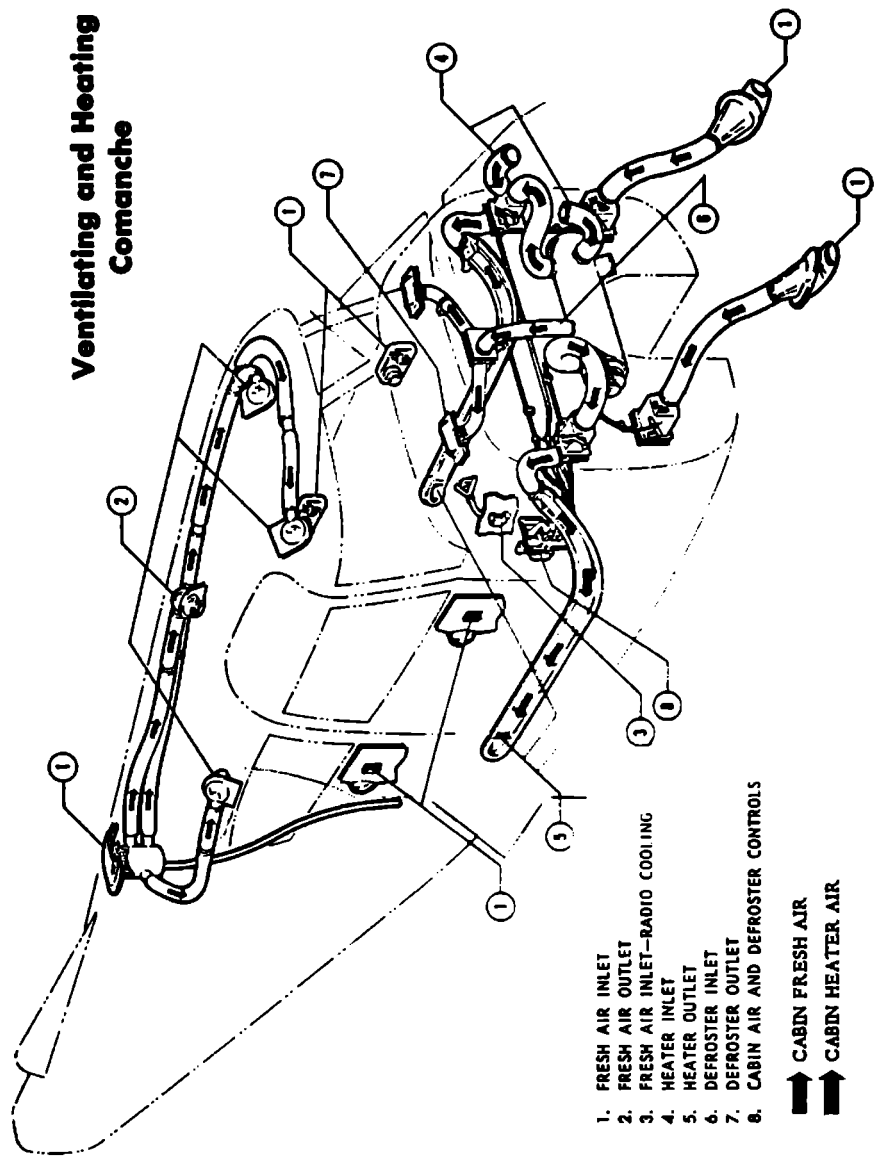

- 1. FRESH AIR INLET
- 2. FRESH AIR OUTLET
- 3. FRESH AIR INLET-RADIO COOLING
- 4. HEATER INLET
- 5. HEATER OUTLET
- 6. DEFROSTER INLET
- 7. DEFROSTER OUTLET
- 8. CABIN AIR AND DEFROSTER CONTROLS

 CABIN FRESH AIR  
 CABIN HEATER AIR

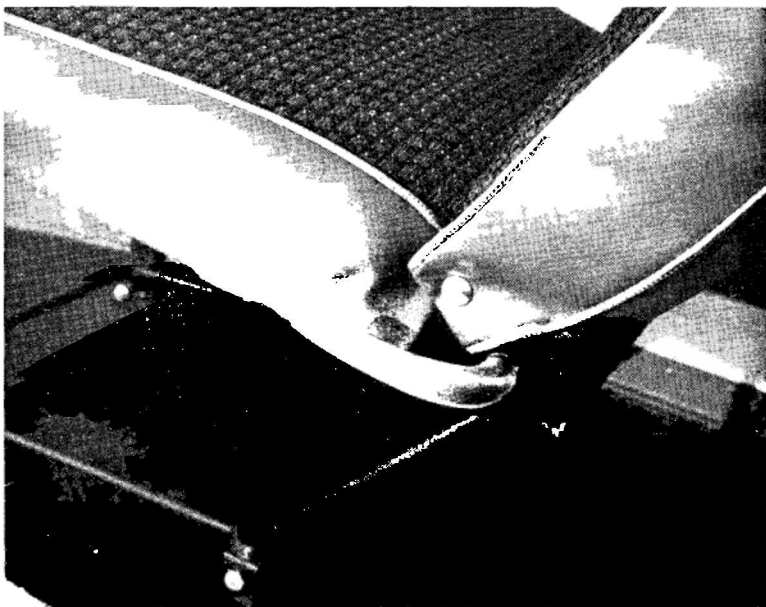
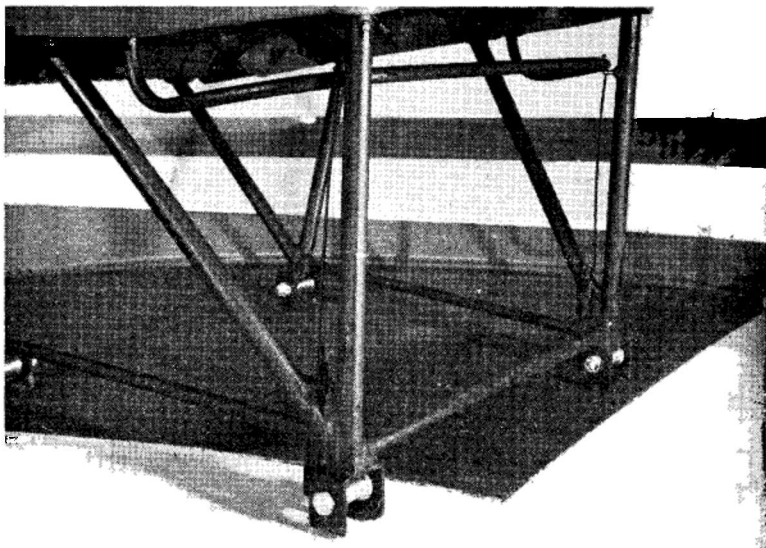

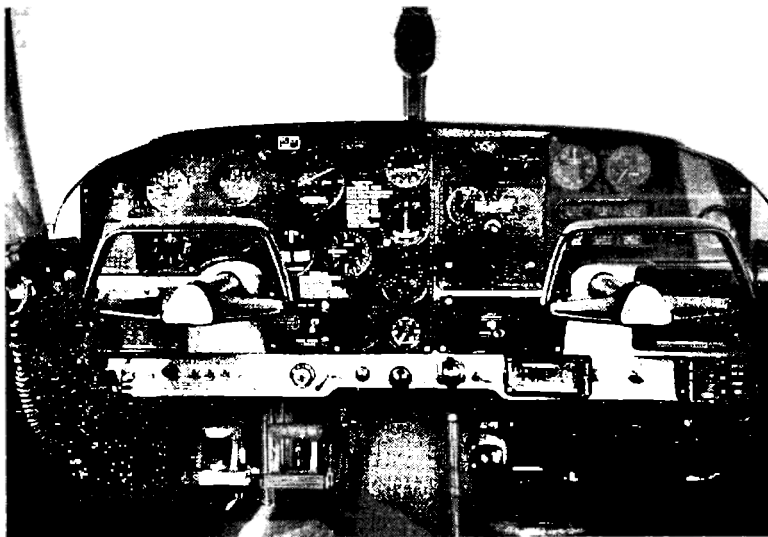

on the engine. The Turn and Bank is an electrically operated instrument and serves as a standby for the Gyro's in case of vacuum system failure.

Radio units are installed in the center of the panel. Radio power supplies are mounted in the fuselage, aft of the baggage compartment.

Front seats are adjustable through a long range for pilot comfort and to facilitate entry and exit. They are easily removed by taking out the stops at the end of the mounting tracks and sliding the seats off their tracks.

The rear seat back is adjusted to various fore and aft positions by use of the latches at the outboard upper corners. The entire rear seat is removed quickly by disengaging the aft seat bottom tube from its attachment clamps, detaching the latches behind the top of the seat back, removing the center safety belt bolt, then lifting both the seat and the back as one unit from the cockpit.

## SECTION TWO

OPERATING INSTRUCTIONS		Page
I. Preflight	. . . . .	21
II. Starting	. . . . .	22
III. Warm-up and Ground Check	. . . . .	22
IV. Takeoff, Climb, Stalls	. . . . .	23
V. Cruising	. . . . .	24
VI. Approach and Landing	. . . . .	25
VII. Emergency Procedures	. . . . .	27
VIII. Mooring	. . . . .	29
IX. Weight and Balance	. . . . .	31
X. Operating Tips	. . . . .	31

**753 570**  
**740212**

## **OPERATING INSTRUCTIONS**

### **I. Preflight:**

Be sure that you have been thoroughly checked out before operating this aircraft.

The following safety procedure instructions must become an integral part of the aircraft owner's operational routine and/or pre-flight inspection.

Before each flight, visually inspect the airplane, and/or determine that:

- (1) The tires are satisfactorily inflated and not excessively worn.
- (2) The landing gear oleos and shock struts operate within limits.
- (3) The propellers are free of detrimental nicks.
- (4) The ground area under propeller is free of loose stones, cinders, etc.
- (5) The cowling and inspection opening covers are secure.
- (6) There is no external damage or operational interference to the control surfaces, wings or fuselage.
- (7) The windshield is clean and free of defects.
- (8) There is no snow, ice or frost on the wings or control surfaces.
- (9) The tow-bar and control locks are detached and properly stowed.
- (10) The fuel tanks are full or are at a safe level of proper fuel.
- (11) The fuel tank caps are tight.
- (12) The fuel system vents are open.
- (13) The fuel strainer and fuel lines are free of water and sediment by draining fuel strainer once a day.
- (14) The fuel tanks and carburetor bowls are free of water and sediment by draining once a week.
- (15) There are no obvious fuel or oil leaks.
- (16) The engine oil is at proper level.
- (17) The brakes are working properly.
- (18) The radio equipment is in order.

(19) The weather is satisfactory for the type of flying you expect to do.

(20) All required papers are in order and in the airplane.

(21) Upon entering the plane, ascertain that all controls operate normally, that the landing gear and other controls are in proper positions and that the door is locked.

## **II. Starting:**

When the engine is cold, (under 40° F.) prime three to five strokes; if extremely cold, pull the propeller through by hand four to six times before turning on the key ignition to the starting position. The throttle should be open about one-quarter inch for easiest starting.

If the engine does not start in the first few revolutions, open the throttle wide while the engine is turning over. This unloads the engine if it is over-rich. If this procedure does not start the engine, continue to load the cylinders by priming or unload by opening the throttle. If the engine still does not start, check for malfunction of the ignition or fuel system.

When the engine is warm, (over 40° F.) do not prime but turn ignition switch to starting position immediately. Warm start priming can be accomplished by pumping the throttle, however care should be taken not to overload the engine this way. It is not necessary to turn the electric fuel pump on for starting.

## **III. Warm Up and Ground Check:**

As soon as the engine starts, the oil pressure should be checked. If no pressure is indicated within thirty seconds, stop the engine and determine the trouble.

Warm up the engine at 800 to 1200 RPM for not more than two minutes in warm weather, four minutes in cold weather. If electrical power is needed from the generator, the engine can be warmed up at 1200 RPM at which point the generator cuts in. The magnetos should be checked at 2000 RPM, the drop not to exceed 125 RPM with manifold pressure of 15" HG. The engine is warm enough for take off when the throttle can be opened without the engine faltering.

Carburetor heat should be checked during the warm up to make sure the heat control operation is satisfactory and to clear out the carburetor if any ice has formed. It should also be checked



in flight occasionally when outside air temperatures are between 20°F and 70°F to see if icing is occurring in the carburetor. In most cases when an engine loses manifold pressure without apparent cause, the use of carburetor heat will correct the condition.

When carburetor heat is applied, cold air entering the induction system is taken from a rear baffle to an exhaust pipe shroud, then to the carburetor; it is not filtered. For this reason carburetor heat should not be used on the ground in dusty conditions except momentarily during the run-up. Dust taken into the intake system can damage the engine severely, and caution must always be exercised during ground operation to prevent dust from entering the engine.

The propeller control should be moved through its normal range during the warm up to check for proper operation, then left in the full high RPM position.

During the propeller check as during other ground operation, care must be taken not to run-up the engine with the propeller over loose stones, cinders or other objects which can be picked up by the propeller, and which frequently cause extensive damage to the propeller blades.

#### **IV. Take-Off, Climb and Stalls:**

Just before take-off the following should be checked:

- |                    |                            |
|--------------------|----------------------------|
| (1) Controls free. | (6) Carburetor heat off.   |
| (2) Flaps up.      | (7) Fuel on proper tank.   |
| (3) Tab set.       | (8) Electric fuel pump on. |
| (4) Propeller set. | (9) Engine gauges normal.  |
| (5) Mixture rich.  | (10) Door latched.         |

After the take-off has proceeded to the point at which a landing can no longer be made wheels down in the event of power failure, the wheels should be retracted. For maximum rate of climb, the propeller and throttle controls should be left at take-off power. For reduced power climbs, the RPM can be reduced to 2400 or 2500 RPM, with full throttle, or manifold pressure can be reduced as desired.

The best rate of climb is obtained at 96 MPH indicated airspeed at sea level on the 180, 95 MPH on the 250. This speed should be decreased about 1 MPH per thousand feet of altitude, so that at 10,000 feet, the best airspeed for maximum rate of climb is 86 MPH. A good rate of climb is obtained at lower altitudes at 100 to 110 MPH, while forward speed is increased. Reducing the climb-

ing airspeed below 95 MPH at low altitudes has the added disadvantage of cutting down forward visibility, so no speeds below that figure are recommended.

The gross weight stalling speed of the two Comanche models with full flaps is 61 and 65 MPH respectively. The stall speed increases about 5 MPH with flaps up. All controls are effective at speeds down to the stalling speed, and stalls are gentle and easily controlled.

### CAUTION

In keeping with general practice for all aircraft, it is recommended that when flying in turbulent air or active weather such as storm conditions, that a satisfactory margin be maintained between the operating cruise speed and the Vne red line so as to allow for inadvertent speed buildups which may occur through the atmospheric conditions or distractions caused by these conditions.

## V. Cruising:

The cruising speed of the Comanche models is determined by many factors including power setting, altitude, temperature, load, and equipment installed on the airplane.

For the 180 Comanche, the normal recommended cruising speed is 160 MPH at 75% power at 8000 feet altitude. This power setting is obtained under standard conditions at 2400 RPM and about 22" M. P. Fuel consumption at this speed approximates 10 gallons per hour. This gives a cruising range with standard fuel of 5 hours or 300 miles, and with reserve fuel 6 hours or 960 miles.

The 250 Comanche has a maximum recommended cruising speed of 181 MPH at 75% power at 7000 feet, 2400 RPM and 22.6" M. P. Fuel consumption at this speed approximates 14 gallons per hour. This gives a cruising range with standard fuel of 4.3 hours or 740 miles, and with auxiliary fuel cells installed a range of 6.4 hours or 1100 miles.

To keep engine wear, fuel consumption, and noise at reasonable levels, cruising RPM's from 2100 to 2400 are recommended, with appropriate Manifold Pressures to obtain power settings of 65% to 75% power at low and intermediate altitudes.

With the Hartzell propeller installation on the 180 or 250, Manifold Pressures of more than 23.5" should not be used at less than 2250 RPM to avoid undesirable propeller stresses. Otherwise, there are no power setting limitations.

For minimum fuel consumption and maximum efficiency, the best power settings during cruising flight are with minimum RPM and the necessary Manifold Pressures to obtain a given percent of power, consistent with the above limitations. Engine smoothness and noise level should be major factors in determining the best RPM.

Use of the mixture control in cruising flight reduces fuel consumption significantly, especially at higher altitudes. The mixture should always be leaned during cruising operation over 5000 feet altitude, and normally also at lower altitudes at the pilot's discretion.

The continuous use of carburetor heat during cruising flight increases fuel consumption and reduces power and performance. Unless icing conditions in the carburetor are severe, do not cruise with the heat on. Apply full heat only for a few seconds at intervals determined by icing severity.

In order to keep the airplane in best lateral trim during cruising, the fuel should be used alternately from each tank. On the 180 Comanche, it is recommended that one tank be used for one hour after take off, then the opposite tank used for two hours, and then the first tank until the fuel runs completely out. This will take approximately two hours if the tanks were full, including the reserve quantity, at take off, and will leave about one more hour's fuel left in the second tank. On the 250, a similar procedure should be used keeping the fuel load in an approximate balance to avoid wing heaviness. If auxiliary tanks are installed, it is suggested the fuel in the two auxiliary tanks be used first.

## **VI. Approach and Landing:**

During the approach, the landing gear can be lowered at speeds under 150 MPH, preferably on the downwind leg. The flaps can be lowered at speeds of up to 125 MPH, if desired. For final approach, trim the aircraft to approximately 85 MPH (PA-24-180), 90 MPH (PA-24-250) with full flaps, or approximately 90 MPH (PA-24-180), 95 MPH (PA-24-250) with no flaps. The propeller should be set at high

RPM to facilitate an emergency go-around if needed. Carburetor heat generally is not applied during landing unless icing conditions are suspected. If a landing is aborted move the carburetor heat to the off position immediately if full power is desired.

The amount of flap used during landings and the speed of the aircraft at contact should be varied according to the wind, the landing surface, and other factors. It is always best to contact the ground at the minimum practicable speed consistent with landing conditions.

Normally, the best technique for short and slow landings is to use full flap and a small amount of power, holding the nose up as long as possible before and after ground contact. In high wind conditions, particularly in strong crosswinds, it may be desirable to approach the ground at higher than normal speeds, with partial or no flap.

Maximum braking effect during short landings can be obtained by holding full back on the control wheel with flaps up while applying brakes. This forces the tail down and puts more load on the main wheels, resulting in better traction.

#### Landing Check List:

- (1) Mixtures rich.
- (2) Propeller set.
- (3) Carburetor heat off (unless icing conditions exist).
- (4) Electric fuel pump on.
- (5) Fuel selector on proper tank.
- (6) Landing gear down (under 150 MPH, check green light on, warning horn off, gear emergency handle in forward position).
- (7) Flaps down (under 125 MPH).

## VII. Emergency Procedures:

Emergency landing gear extension is accomplished with the telescoping manual extension lever. This control can be used only to extend the gear if the electrical actuating system has failed, and not to retract the gear manually without the use of the electric motor. With the electric motor disengaged from the gear torque tube, as required in extending the gear manually, there is no mechanism for holding the gear in the up position, so that the gear will not stay up if retracted manually.

To extend the gear, remove the cover over the emergency disengage control, located between the two front seats, and follow the instruction on the back of this cover, as follows:

- (1) Airspeed not over 100 MPH.
- (2) Landing gear switch in center "off" position.
- (3) Disengage electric motor by pushing motor release arm forward through full travel.
- (4) Pull out emergency extension handle to full length.
- (5) Push handle forward full travel to extend landing gear.

If it should become necessary to extend the gear manually, at the completion of the flight the trouble should be determined with the airplane on jacks. Then to return to normal electrical gear operation, re-engaging the electric motor to the landing gear extension torque tube should be done as follows:

- (1) Landing gear switch in center "off" position.
- (2) Pull landing gear emergency extension handle about half way back, allowing gear to hang partially retracted.
- (3) With landing gear control switch, move end of the electric motor drive shaft into position about half way back, so that the slot in the drive shaft is near the mating pin on the torque tube.
- (4) Using the extension handle, move the torque tube pin slightly back and forth until it can be engaged with the drive shaft slot, then push the parts together.
- (5) Lock the drive shaft to the torque tube by pulling the motor release arm full back to the normal locked position.
- (6) Safety-wire the release arm in the locked position.



### Gear-Up Landing:

A gear-up landing should only be made during an emergency (1) when the surface is too soft or rough to permit a gear down landing, (2) when a field is too short for a gear-down landing, which might cause more damage through hitting obstructions than the gear-up landing would cause, (3) when a water landing is necessary.

In the event of a gear-up landing, make a normal approach as with gear down, leave flaps up (to reduce flap and wing damage), close the throttle and cut the master and ignition switches during the flare out, turn the fuel selector off, and contact the ground at minimum speed.

**Engine Failure:**

The most common cause of engine failure is mismanagement or malfunction of the fuel system. Therefore, the first step to take after engine failure is to move the fuel selector valve to the tank not being used. This will often keep the engine running even if there is no apparent reason for the engine to stop on the tank being used.

If changing to the opposite fuel tank does not restore the engine:

- (1) Check fuel pressure and turn on electric fuel pump, if off.
- (2) Push mixture control to full rich.
- (3) Apply carburetor heat.
- (4) Check ignition switch.

**VIII. Mooring:**

The Comanche should be moved on the ground with the aid of the nose wheel-tow-bar provided with each plane and installed in the baggage compartment on the bottom of the hat shelf.

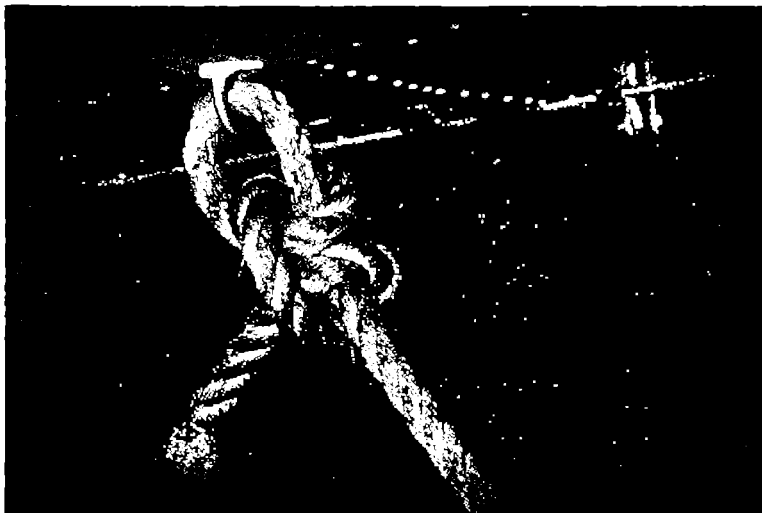

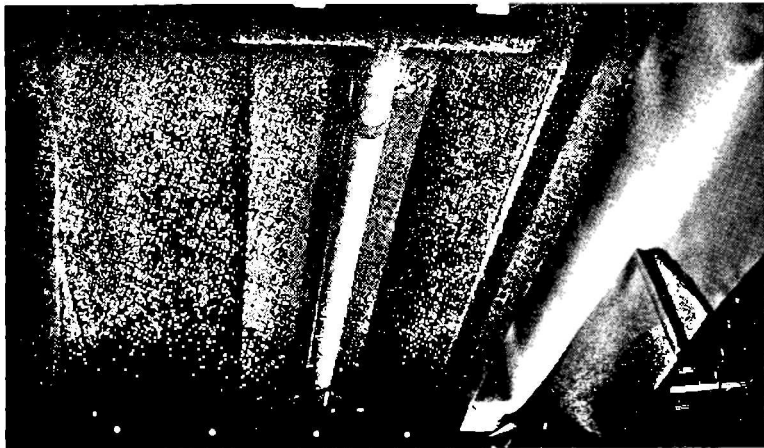
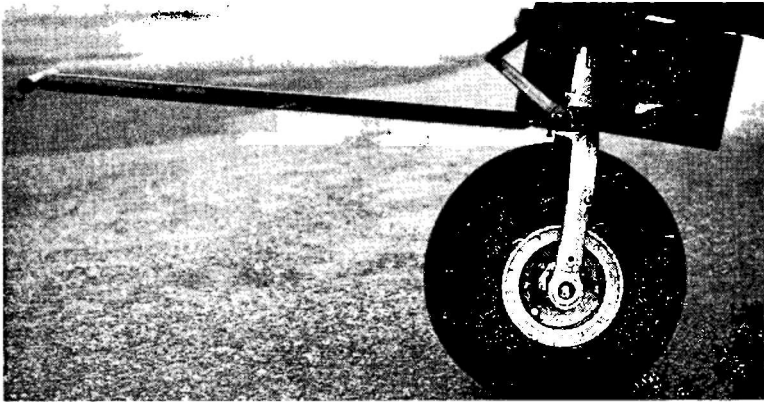

Tie-down ropes for mooring the airplane can be fastened to the wing tie-down rings and the tail skid.

The aileron and elevator controls should be secured by means of the safety belt to prevent control surface damage. The rudder is held in position by its connections with the steerable nosewheel and does not need to be secured except under unusually high wind conditions. The flaps are locked in position when left full up, so should always be retracted for mooring to prevent wind damage and permit using the flap as a step.



## **IX. Weight and Balance:**

For weight and balance data, see the Flight Manual and Weight and Balance form supplied with each airplane, which gives the exact weight of the airplane and permissible center of gravity conditions.

## **X. Operating Tips:**

In the operation of the Comanche, as in that of any other type of aircraft, there are a few points of technique and information that apply particularly to this model. The following Operating Tips may be helpful in the operation of the Comanche:

(1) Remember that when the navigation lights are on the gear position lights are very dim.

(2) Learn to trim the airplane for take-off so that only a very light back pressure on the wheel is required to lift the ship off the ground.

(3) On take-off, do not retract the gear prematurely. The aircraft may settle and make contact with the ground because of lack of flying speed, atmospheric conditions or rolling terrain.

(4) The best speed for take-off is at about 65 MPH under normal conditions. Trying to pull the airplane off the ground at too low an airspeed will increase the take-off roll rather than decrease it.

(5) Although it is permissible to extend the landing gear at speeds up to 150 MPH, the loads on the landing gear extension motor and on the gear doors are much lower if slower speeds are used. For this reason, it is recommended that unless there is good reason to lower the gear at a higher speed, it should normally be extended at speeds below 125 MPH.

(6) The flaps can be lowered at airspeeds up to 125 MPH. To reduce flap operating loads, however, it is desirable to slow the airplane to 100 MPH or less before extending the flaps. At these reduced speeds, the load that the pilot must apply to the flap lever is very light.

(7) During gear operation, keep the floor area under the emergency gear lever clear. Restriction to movement of the lever will cause the gear motor circuit breaker to open.

(8) Always ascertain position of landing gear by the position of the emergency gear lever as well as the gear position lights.

(9) If, under unusual circumstances, the landing gear motor is apparently being overloaded and the circuit breaker opens repeatedly, the electric motor can be assisted by applying light hand pressure to the emergency gear lever.

(10) Before attempting to reset any circuit breaker, allow a two to five minute cooling off period.

(11) When landing and upon making contact with the ground on the rear wheels, neutralize the rudder pedals, apply additional back pressure to the control wheel and retract the flaps. This gives best directional control on the ground and provides for full effectiveness of the brakes during the landing roll.

(12) The shape of the fuel tanks is such that in certain maneuvers the fuel may move away from the tank outlet. If the outlet is uncovered, the fuel flow may be interrupted and a temporary loss of power may result. Pilot's can prevent inadvertent uncovering of the outlet by having adequate fuel in the tank selected and avoiding maneuvers which could result in uncovering the outlet.

Running turning takeoffs should be avoided as fuel flow interruption may occur.

Prolonged slips or skids in any pitch attitude or other unusual or abrupt maneuvers which could cause uncovering of the fuel outlet must be avoided.

(13) The rudder pedals are suspended from a torque tube which extends across the fuselage. The pilot should become familiar with the proper positioning of his feet on the rudder pedals so as to avoid interference with the torque tube when moving the rudder pedals or operating the toe brakes.

<b>SECTION THREE</b>		<b>Page</b>
<b>PERFORMANCE CHARTS</b>	. . . . .	33-40
<b>POWER CHARTS</b>	. . . . .	41-42
<b>POWER TABLES</b>	. . . . .	43-44

**PIPER COMANCHE  
PA24 180 H.P., 250 H.P.**

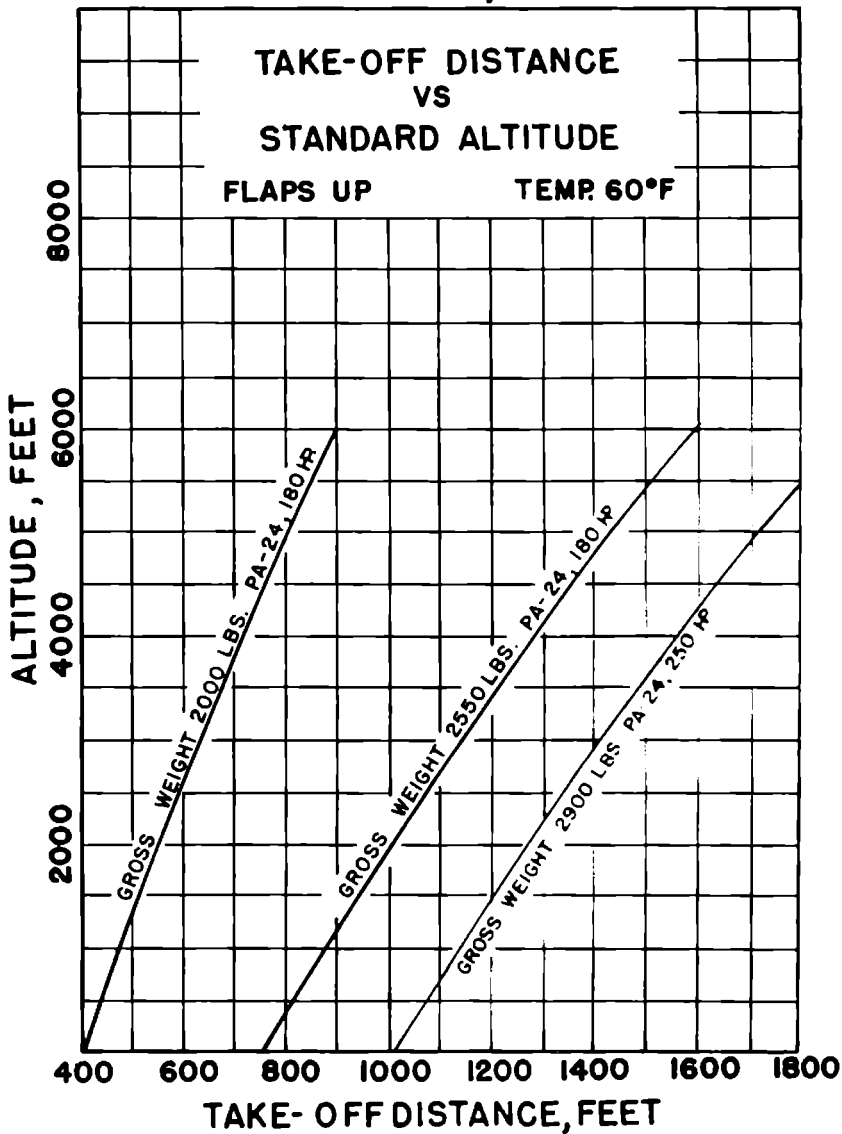

PIPER COMANCHE

PA24, 180 H.P.

TRUE AIR SPEED  
VS  
STANDARD ALTITUDE  
GROSS WEIGHT 2550 LBS.

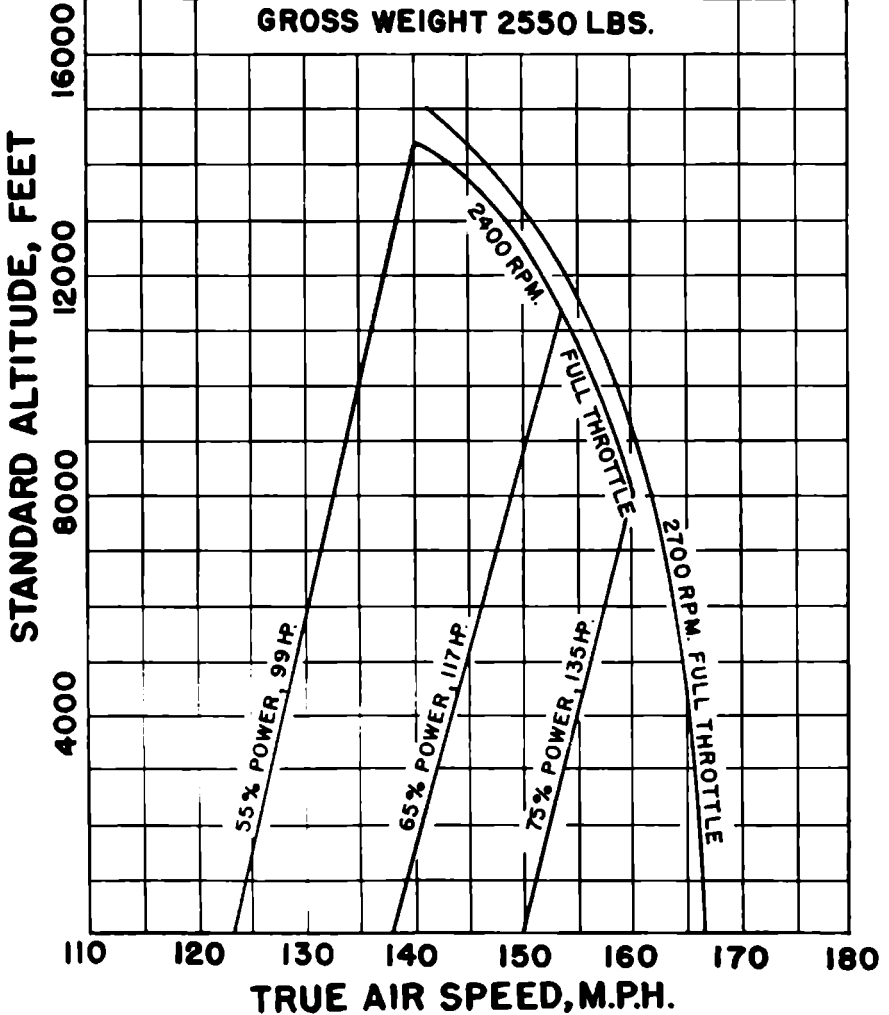

# PIPER COMANCHE

## PA24, 250 H.P.

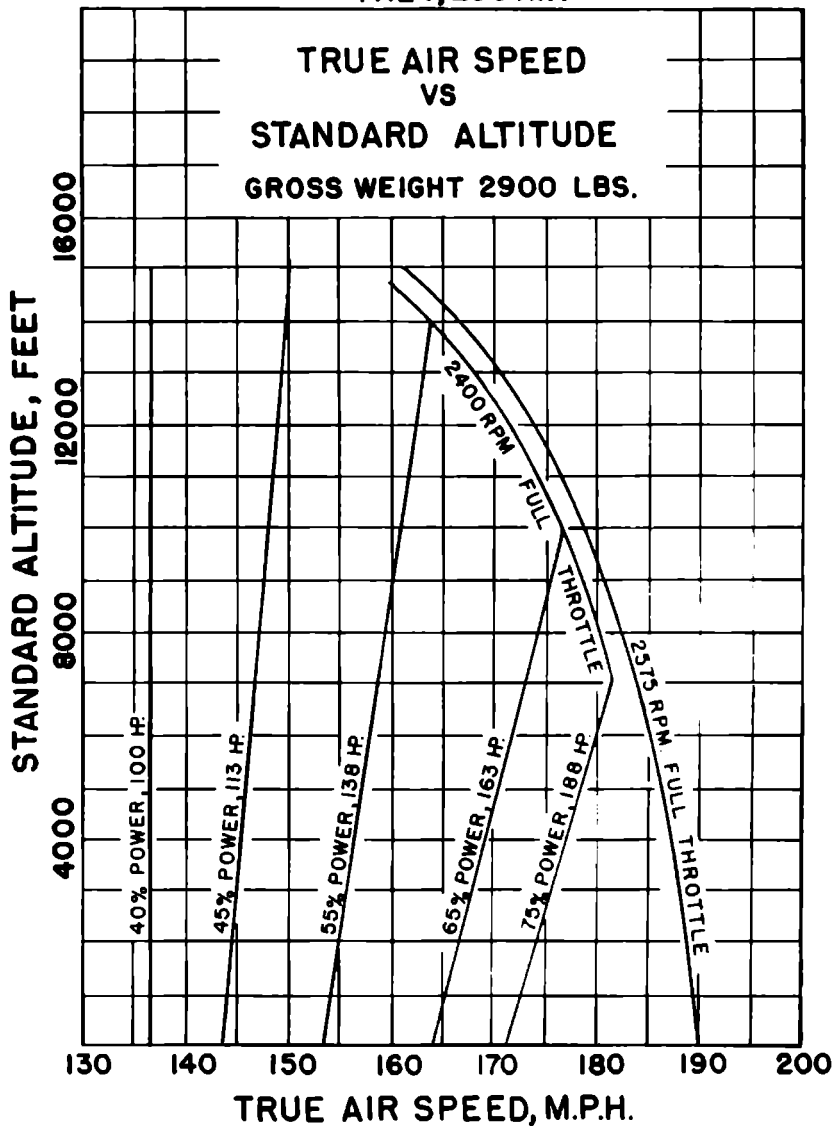

# PIPER COMANCHE

## PA24,180 H.P.

### RANGE VS STANDARD ALTITUDE

GROSS WEIGHT 2550 LBS.

MIXTURE LEANED

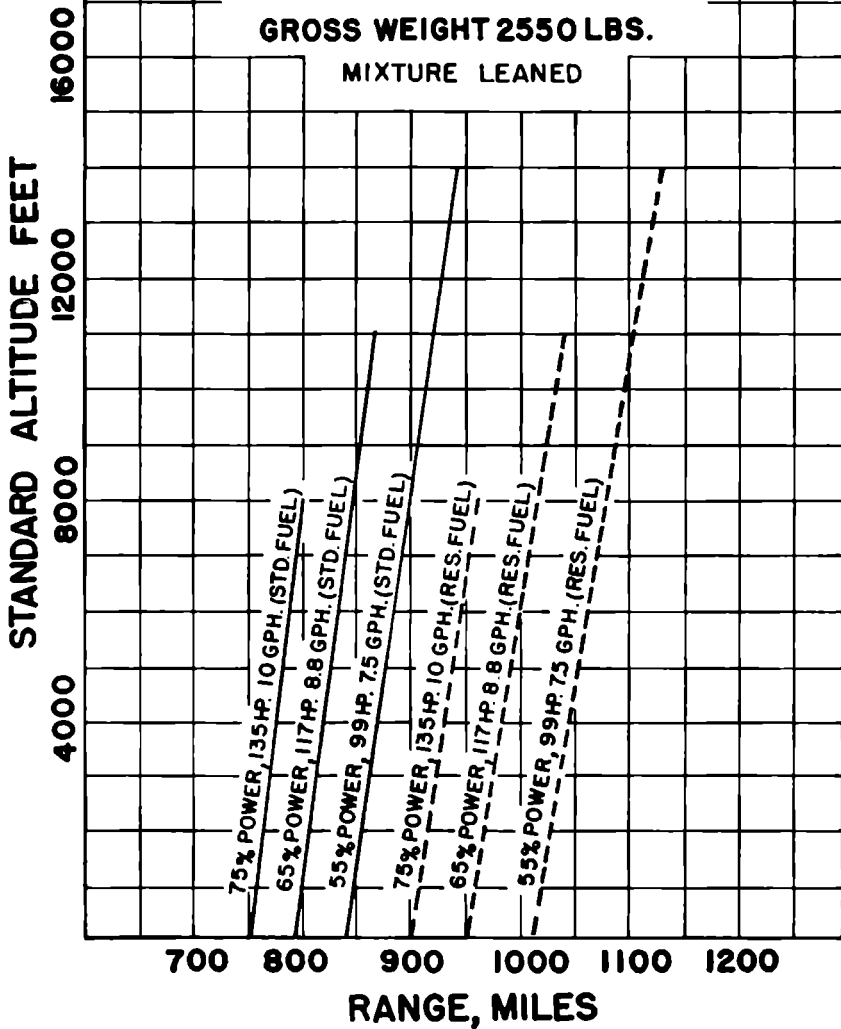

**PIPER COMANCHE  
PA24, 250 H.P.**

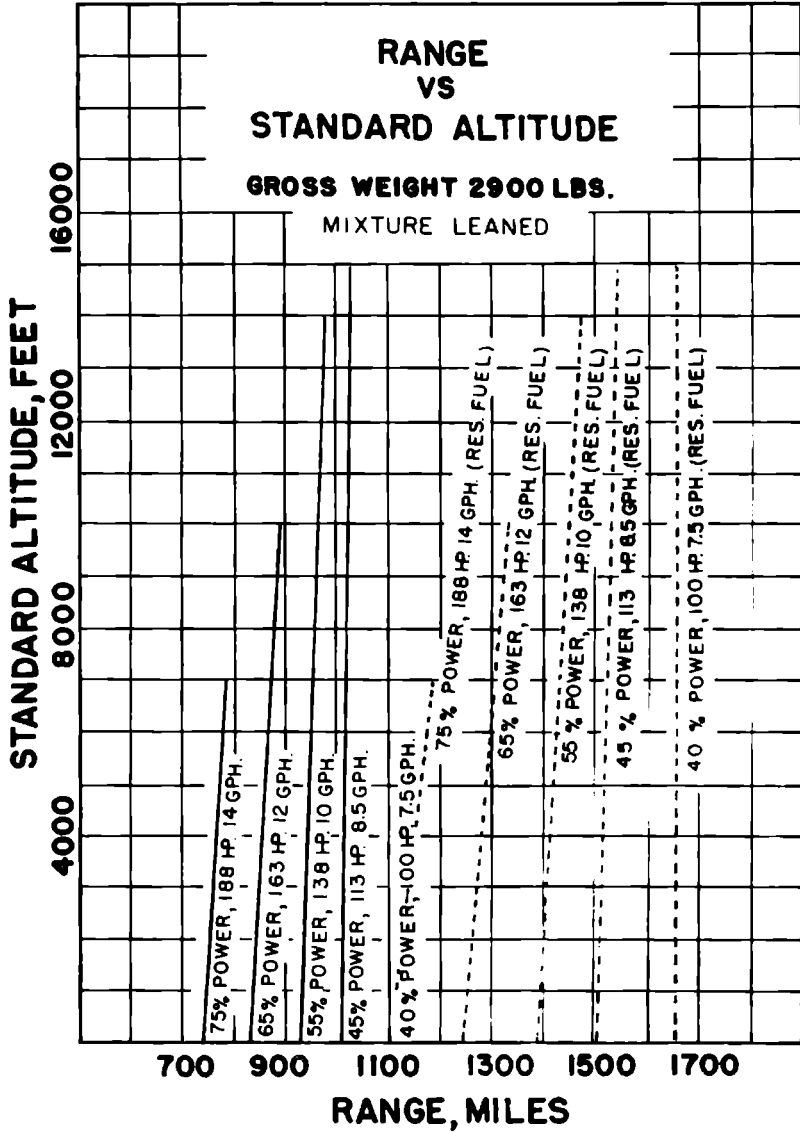



# PIPER COMANCHE

## PA24, 180 H.P.

### RATE OF CLIMB VS STANDARD ALTITUDE

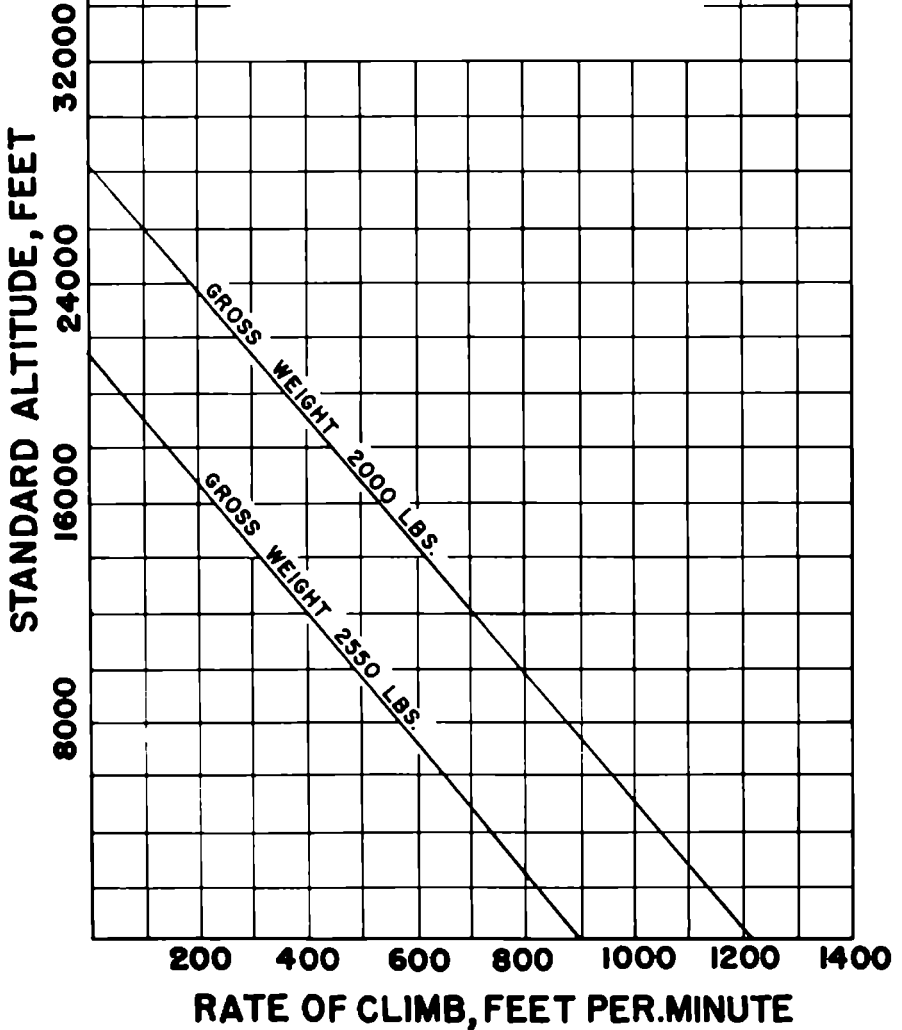

**PIPER COMANCHE**

**PA24,250H.P.**

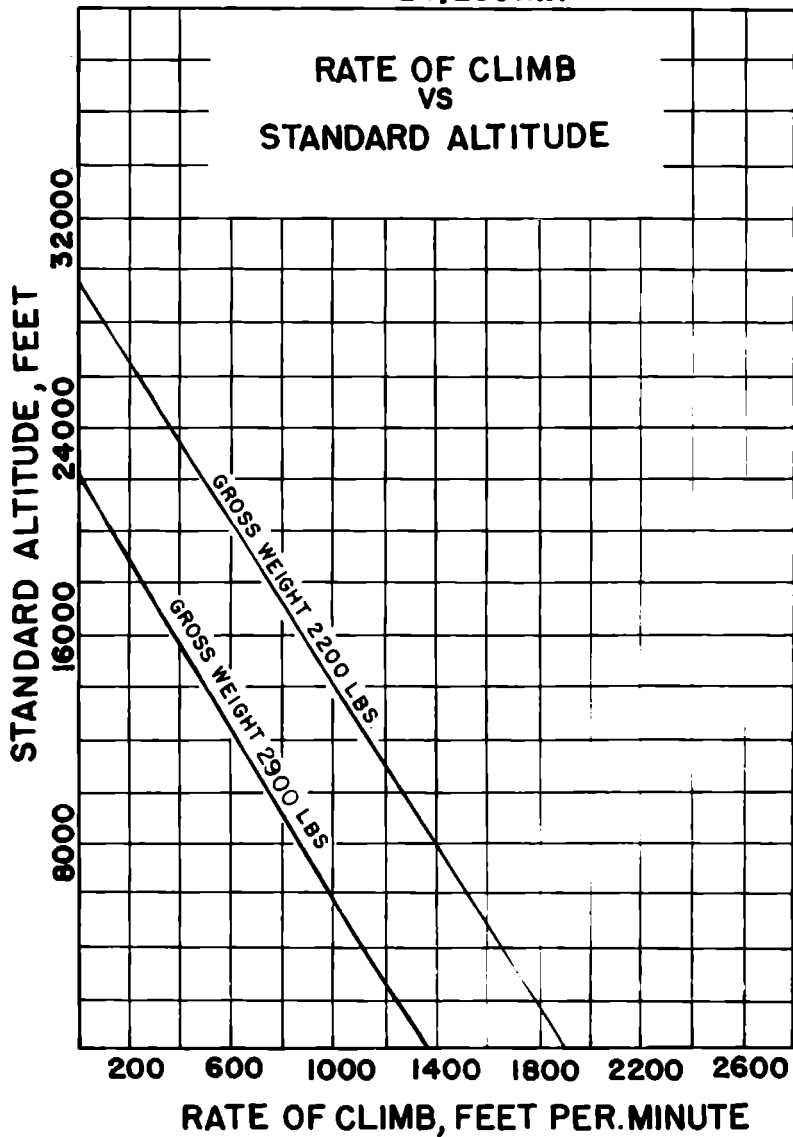

**PIPER COMANCHE  
PA24 180H.P.,250H.P.**

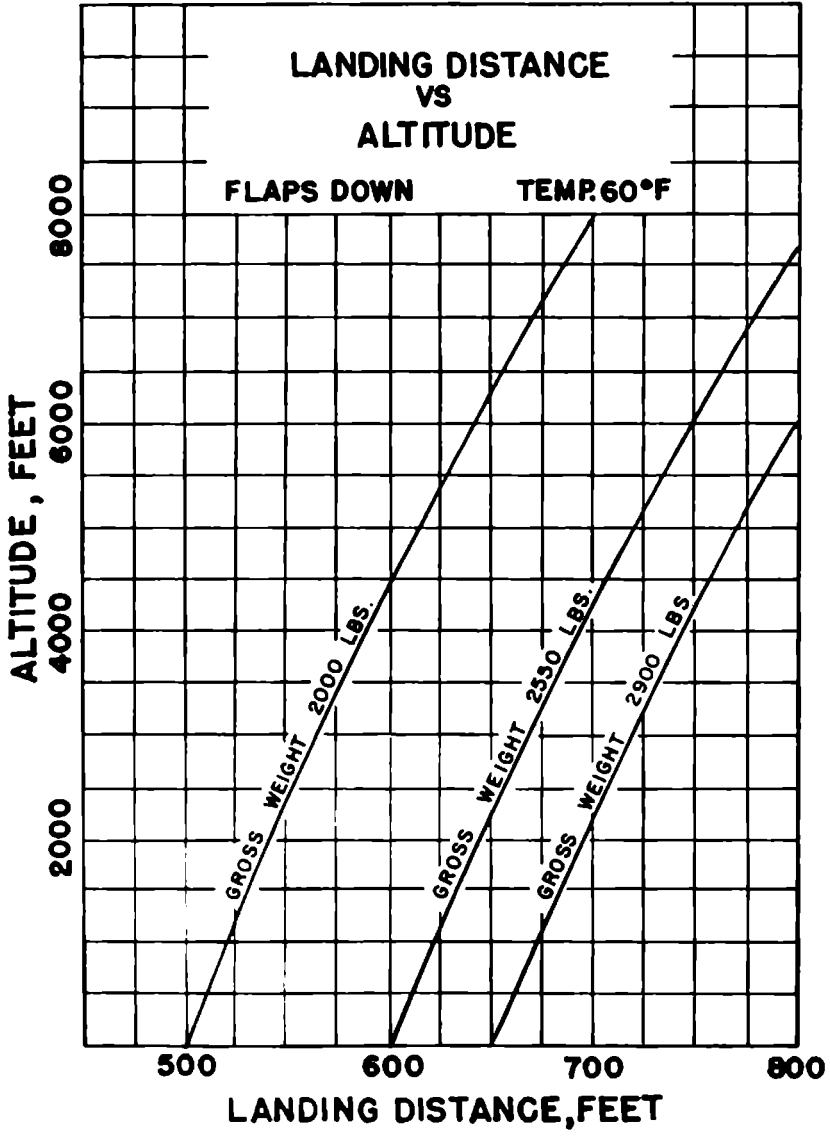





## Power Setting Table — Lycoming Model O-360-A, 180 HP Engine

Press. Alt. 1000 Feet	Std. Alt. Temp. °F	99 HP — 55% Rated Approx. Fuel 7.4 Gal./Hr. RPM AND MAN. PRESS.			117 HP — 65% Rated Approx. Fuel 8.8 Gal./Hr. RPM AND MAN. PRESS.			135 HP — 75% Rated Approx. Fuel 10 Gal./Hr. RPM AND MAN. PRESS.				
		2100	2200	2300	2400	2100	2200	2300	2400	2200	2300	2400
SL	59	20.9	20.3	19.8	19.3	23.3	22.7	22.1	21.5	25.1	24.5	23.9
1	55	20.7	20.1	19.6	19.1	23.1	22.4	21.8	21.3	24.8	24.2	23.6
2	52	20.4	19.8	19.3	18.8	22.8	22.1	21.6	21.0	24.6	24.0	23.4
3	48	20.2	19.6	19.1	18.6	22.5	21.9	21.3	20.8	24.3	23.7	23.2
4	45	19.9	19.3	18.9	18.4	22.3	21.6	21.1	20.6	24.0	23.5	22.9
5	41	19.7	19.1	18.7	18.2	22.0	21.4	20.9	20.3	23.8	23.2	22.7
6	38	19.5	18.9	18.4	18.0	21.8	21.1	20.6	20.1	—	23.0	22.5
7	34	19.3	18.7	18.2	17.8	21.5	20.9	20.4	19.9	—	—	22.2
8	31	19.0	18.4	18.0	17.6	21.3	20.7	20.2	19.7	—	—	—
9	27	18.8	18.2	17.8	17.4	—	20.4	20.0	19.5	—	—	—
10	23	18.6	18.0	17.6	17.2	—	—	19.8	19.3	—	—	—
11	19	18.4	17.8	17.4	17.0	—	—	—	19.1	—	—	—
12	16	18.2	17.6	17.2	16.8	—	—	—	—	—	—	—
13	12	—	17.4	17.0	16.7	—	—	—	—	—	—	—
14	9	—	—	16.8	16.5	—	—	—	—	—	—	—
15	5	—	—	—	16.3	—	—	—	—	—	—	—

To maintain constant power, correct manifold pressure approximately 0.17" Hg for each 10° F. variation in carburetor air temperature from standard altitude temperature. Add manifold pressure for air temperatures above standard; subtract for temperatures below standard.

## Power Setting Table — Lycoming Model O-540-A, 250 HP Engine

Press. Alt. 1000 Feet	Std. Alt. Temp. °F.	130 HP — 55% Rated Approx. Fuel 10.3 Gal./Hr. RPM AND MAN. PRESS.			163 HP — 65% Rated Approx. Fuel 12.3 Gal./Hr. RPM AND MAN. PRESS.			188 HP — 75% Rated Approx. Fuel 14.0 Gal./Hr. RPM AND MAN. PRESS.				
		2100	2200	2300	2400	2100	2200	2300	2400	2100	2200	2300
SL	50	21.6	20.3	20.2	19.6	24.2	23.3	22.6	22.0	25.8	25.1	24.3
1	55	21.4	20.6	20.0	19.3	23.9	23.0	22.4	21.8	25.5	24.8	24.1
2	52	21.1	20.1	19.7	19.1	23.7	22.8	22.2	21.5	25.3	24.6	23.8
3	48	20.9	20.1	19.5	18.9	23.4	22.5	21.9	21.3	25.0	24.3	23.6
4	45	20.6	19.9	19.3	18.7	23.1	22.3	21.7	21.0	24.8	24.1	23.3
5	41	20.4	19.7	19.1	18.5	22.9	22.0	21.4	20.8	—	—	23.0
6	38	20.1	19.5	18.9	18.3	22.6	21.8	21.2	20.6	—	—	22.8
7	34	19.9	19.2	18.6	18.0	22.3	21.5	21.0	20.4	—	—	—
8	31	19.6	19.0	18.4	17.8	—	21.3	20.7	20.1	—	—	—
9	27	19.4	18.8	18.2	17.6	—	—	20.5	19.9	—	—	—
10	23	19.1	18.6	18.0	17.4	—	—	—	19.6	—	—	—
11	19	18.9	18.3	17.8	17.2	—	—	—	—	—	—	—
12	16	18.6	18.1	17.5	17.0	—	—	—	—	—	—	—
13	12	—	17.9	17.3	16.8	—	—	—	—	—	—	—
14	9	—	—	17.1	16.5	—	—	—	—	—	—	—
15	5	—	—	—	16.3	—	—	—	—	—	—	—

To maintain constant power, correct manifold pressure approximately 0.17" Hg for each 10° F. variation in carburetor air temperature from standard altitude temperature. Add manifold pressure for air temperatures above standard; subtract for temperatures below standard.

## **SECTION FOUR**

<b>GENERAL MAINTENANCE</b>	<b>Page</b>
<b>I. Leveling and Rigging</b> . . . . .	<b>45</b>
<b>II. Tire Inflation</b> . . . . .	<b>45</b>
<b>III. Battery Service</b> . . . . .	<b>46</b>
<b>IV. Brake Service</b> . . . . .	<b>47</b>
<b>V. Landing Gear Service</b> . . . . .	<b>47</b>
<b>VI. Fuel Requirements</b> . . . . .	<b>49</b>
<b>VII. Care of Air Filter</b> . . . . .	<b>52</b>
<b>VIII. Care of Windshield and Windows</b> . . . . .	<b>53</b>
<b>IX. Serial Number Plate</b> . . . . .	<b>53</b>



## GENERAL MAINTENANCE

### I. Leveling and Rigging:

Leveling the Comanche for purposes of reweighing or rigging is accomplished as follows:

(1) Partially withdraw two machine screws located on the side of the fuselage over the baggage door. These screws are leveling points and the airplane is longitudinally level when a level placed on the head of these screws indicates level.

(2) To put the airplane in a longitudinally level position on scales, first block the main gear oleos to full extension, then deflate the nose wheel tire until the proper position is reached. For rigging purposes only, place airplane on jacks.

(3) To level the airplane laterally, place a level across the floorboard at station 136.5 bulkhead (in baggage compartment between rear spar attachment points).

Rigging: Although the fixed flight surfaces on the Comanche obviously cannot be adjusted in position for rigging purposes, it may be necessary on occasion to check the position of these surfaces. The movable surfaces, with the exception of the flaps, all have adjustable stops as well as adjustments on their cables or push-pull connections, so that their range of movement can be altered. The positions and travels of the various surfaces are as follows:

- (1) Wings:  $5^{\circ}$  dihedral, no twist.
- (2) Stabilator: No dihedral, travel  $13^{\circ}$  up,  $5^{\circ}$  down. —  $-1^{\circ}$ .
- (3) Fin: Should be vertical and in line with center of fuselage.
- (4) Ailerons: Travel  $19^{\circ}$  up,  $15^{\circ}$  down, +  $-1^{\circ}$ .
- (5) Flaps: Travel  $27^{\circ}$  down in three  $9^{\circ}$  increments.
- (6) Rudder: Travel  $25^{\circ}$  left or right, +  $-2^{\circ}$ .

For purposes of changing the lateral trim, a fixed tab is provided on the left aileron which can be adjusted as necessary.

### II. Tire Inflation:

For maximum service from the tires on the Comanche, keep tires inflated to the proper pressure of 27 lbs. on all three tires on the Comanche 180, and 42 lbs. on the main wheels and 27 lbs. on the nose wheel on the Comanche 250. Interchange the tires on the wheels if necessary to produce even wear. All wheels and tires are balanced before original installation, and the relationship of tire, tube and

wheel should be maintained whenever possible upon reinstallation. Out of balance wheels can cause extreme vibration in the landing gear during take off. In the installation of new components, it may be necessary to rebalance the wheels with the tires mounted.

### **III. Battery Service:**

Access to the 12-volt 33-ampere hour battery is through the right rear baggage compartment panel. The stainless steel box has a plastic drain tube which is normally closed off with a clamp, and which should be opened occasionally to drain off any accumulation of liquid.

The battery should be checked frequently for proper fluid level, but must not be filled above the baffle plates. All connections must be clean and tight.

If the battery is not up to proper charge, recharge starting with a charging rate of 4 amps, and finishing with 2 amps. Quick charges are not recommended.

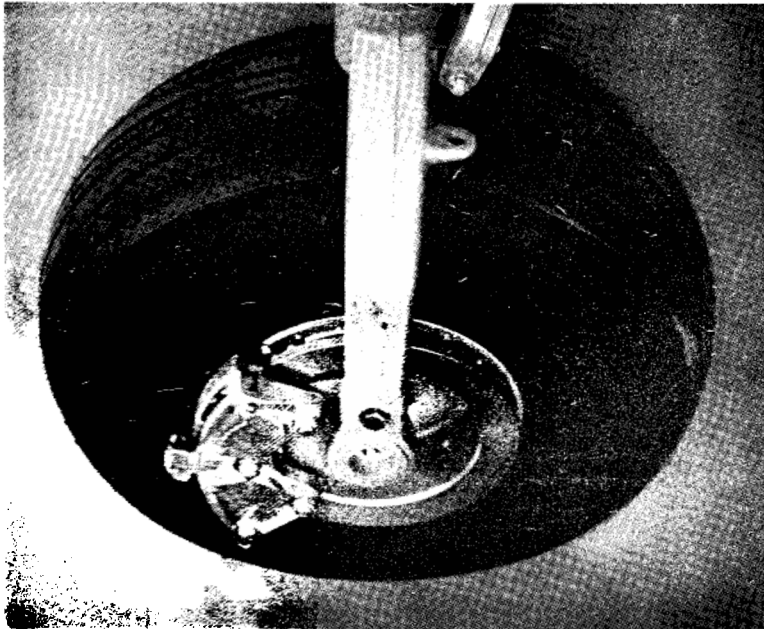

## **IV. Brake Service:**

The brake system is filled with Unavis No. 40 (petroleum base) hydraulic brake fluid. This should be checked at every 100 hour inspection and replenished when necessary, refilling the brake reservoir on the firewall to the indicated level.

No adjustment of brake clearances is necessary on the Comanche brakes. If after extended service the brake blocks become worn excessively, they are easily replaced with new brake segments.

Main wheels are easily removed by taking off the hub nut and withdrawing the axle bolt, the axle retainer cups, the axle, and remove four bolts from the brake assembly after which the wheels slip freely from the wheel fork.

Tires are dismounted from the wheels by deflating the tube, then removing the wheel through-bolts, allowing the wheel halves to be separated.

## **V. Landing Gear Service:**

In jacking up the Comanche for landing gear and other service, a jack kit (available through the Piper Aircraft Distributor Service Departments) should be used. This kit includes two hydraulic





jacks and a tail support. Approximately 300 lbs. of ballast should be placed on the base of the tail support before jacking up the airplane.

Landing gear oleos on the Comanche should be serviced according to instruction on the units. All three oleos should be extended until about 2 $\frac{3}{4}$ " of oleo piston tube is exposed.

To add air to the oleo struts, a strut pump is attached at the air valve and the oleo pumped up to the proper position. To add oil, first release the air through the valve, allowing the oleo to compress

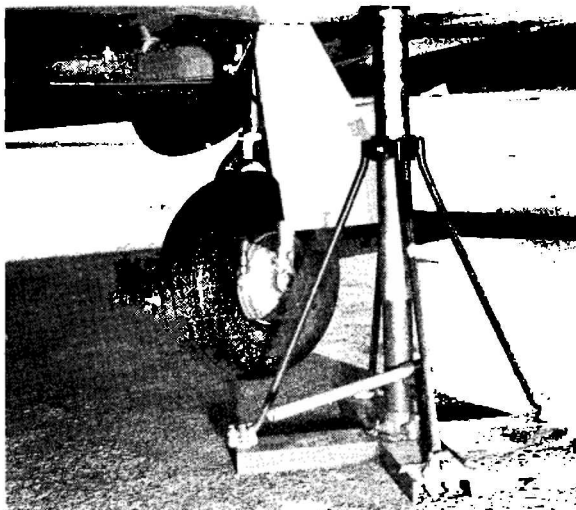

fully. Next remove the air valve core and fill the unit through this opening. Then compress the oleo to within  $\frac{1}{4}$ " of full compression, allowing air and excess oil to escape. Then reinsert the valve core and pump up the strut.

## **VI. Fuel Requirements:**

Aviation Grade 91/96 Octane (minimum) fuel must be used in the Comanche. The use of lower grades of fuel can cause serious engine damage in a very short period of time, and is considered of such importance that the engine warranty is invalidated by such use.

The oil capacity of the Lycoming 0-360-A is 8 quarts, and the minimum safe quantity is 2 quarts. For the 0-540-A, the capacity is 12 quarts and the minimum safe quantity  $2\frac{3}{4}$  qts. The operating oil level is normally kept a quart or more below the maximum to reduce oil consumption. It is recommended that engine oil be changed every 50 hours, or sooner under unfavorable conditions. The following grades are required for the specified temperatures:

Temperatures above 40°F	S. A. E. 50
Temperatures between 10°F and 40°F	S. A. E. 30
Temperatures below 10°F	S. A. E. 20

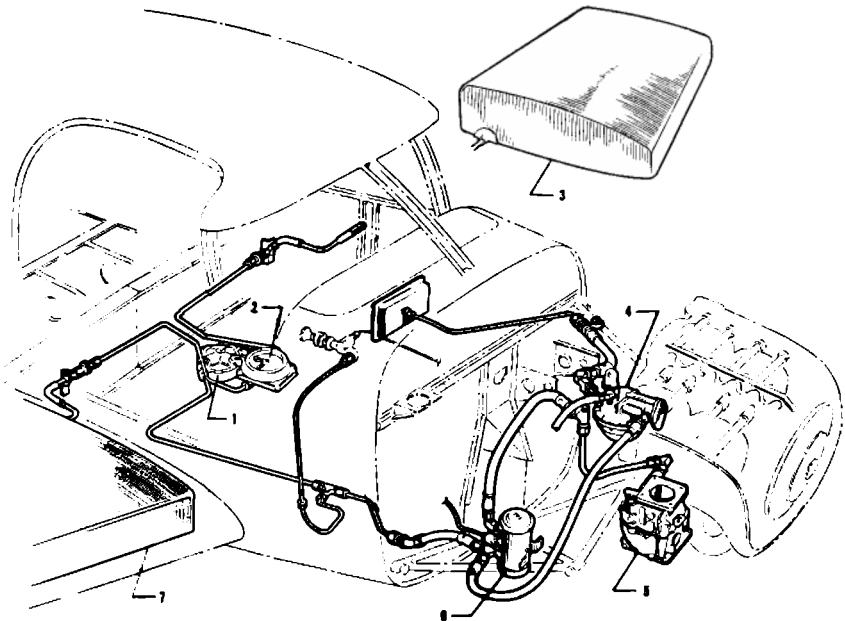

- |                       |                       |
|-----------------------|-----------------------|
| 1. Fuel strainer      | 5. Carburetor         |
| 2. Fuel selector      | 6. Electric fuel pump |
| 3. Left fuel tank     | 7. Right fuel tank    |
| 4. Engine driven pump |                       |

**Fuel System Comanche – 180 H.P.  
PA-24-180**

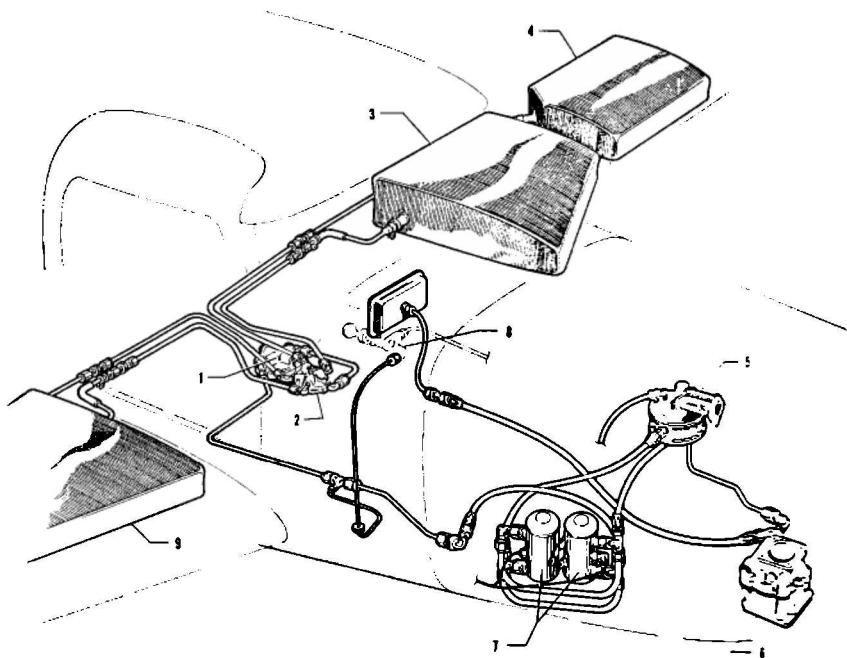

- 1. Fuel strainer
- 2. Fuel selector valve
- 3. Left main tank
- 4. Left auxiliary tank
- 5. Engine driven pump

- 6. Carburetor
- 7. Electric fuel pumps
- 8. Engine primer
- 9. Right main tank

**Fuel System Comanche – 250 H.P.  
(with auxiliary tanks)**

**PA-24-250**

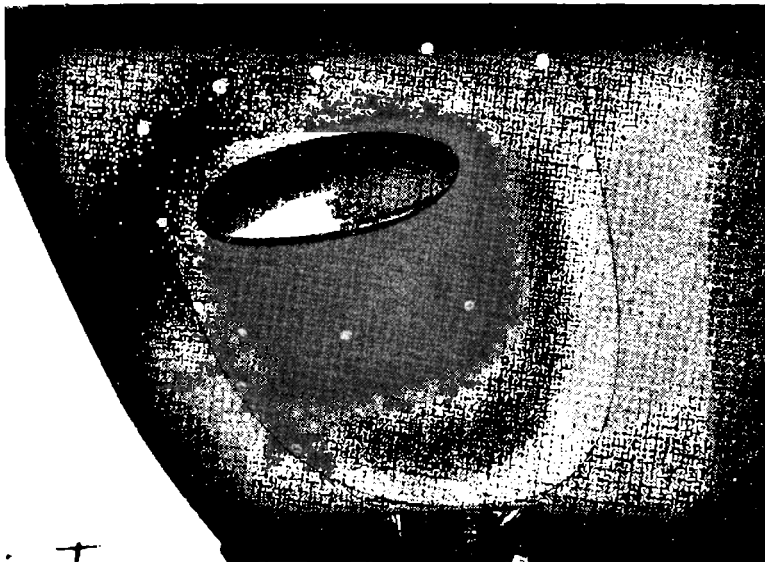

### VII. Care of Air Filter:

The carburetor air filter must be cleaned at least once every fifty hours and depending on the type of condition existing, it may be necessary to clean the filters daily or every five hours. Extra filters are inexpensive and should be kept on hand and used for rapid replacement.

The following cleaning procedure is recommended by the manufacturer of the filter:

- 1 Remove air scoop.
- 2 Remove filter from cowling.
- 3 Tap gently to remove dirt particles. Do not use compressed air.
- 4 Reassemble to cowling and replace scoop.



### **VIII. Care of Windshield and Windows:**

A certain amount of care is required to keep the plexiglas windows clean and clear. The following procedure is recommended:

(1) Flush with clean water and dislodge excess dirt, mud, etc., with your hand.

(2) Wash with mild soap and warm water. Use a soft cloth or sponge. (Do not rub).

(3) Remove oil, grease or sealing compounds with a cloth soaked in kerosene.

(4) After cleaning, apply a thin coat of hard polishing wax. Rub lightly with a soft dry cloth.

(5) A severe scratch or mar can be removed by using jeweler's rouge to rub out scratch, smooth on both sides and apply wax.

### **IX. Serial Number Plate:**

The serial number plate on the Comanche is located on the inside of the baggage door. The serial number of the plane should always be used in referring to the airplane in service or warranty matters.